

UNITED COOLAIR CORPORATION

MARVEL “J” HVAC MICROPROCESSOR CONTROLLER INSTALLATION AND OPERATING MANUAL

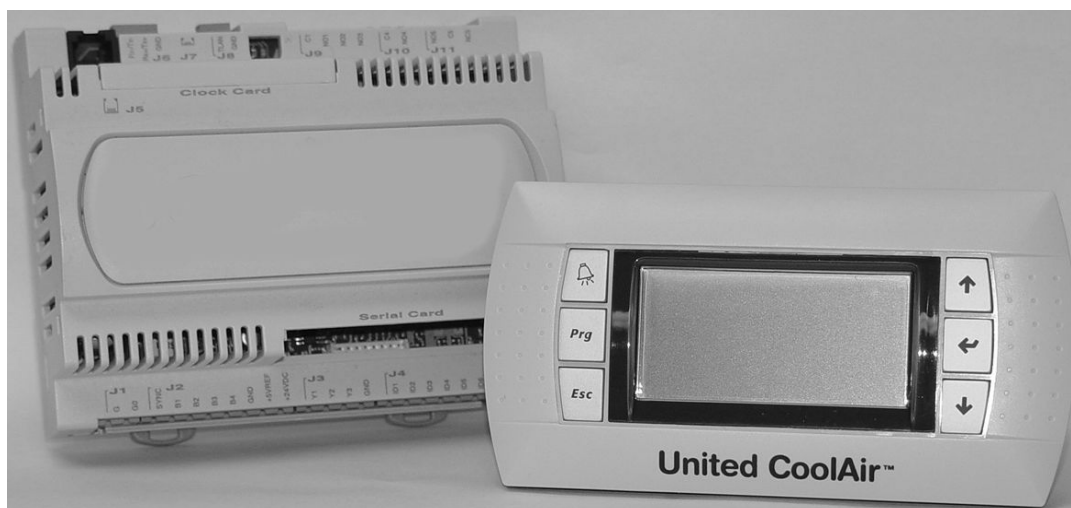

491 E. PRINCESS ST. YORK, PA 17405

PH: (877) 905 – 1111 FAX: (717) 854 – 4462

TABLE OF CONTENTS

| | |
|---|----|
| GENERAL PURPOSE | 3 |
| STANDARD COMPONENTS | 3 |
| BASIC OPTIONS | 3 |
| MARVEL J CONTROL OPERATION | 4 |
| HARDWARE AND ARCHITECTURAL LAYOUT | 8 |
| MARVEL "J" MAIN BOARD | 9 |
| SENSOR INSTALLATION | 10 |
| MARVEL "J" TERMINAL (WALL CONTROL)..... | 12 |
| DISPLAY DIMENSIONS | 13 |
| WALL MOUNTING | 13 |
| CONNECTING CABLE | 14 |
| CONTROL BUTTONS | 15 |
| ALARM BUTTON | 15 |
| PRG BUTTON | 15 |
| ESC BUTTON | 15 |
| UP BUTTON | 15 |
| ENTER BUTTON | 15 |
| DOWN BUTTON | 16 |
| STARTUP | 17 |
| BASIC AND ADVANCED SETUPS | 17 |
| INPUT WIRING | 23 |
| REAL TIME CLOCK BOARD | 24 |
| BUILDING MANAGEMENT SYSTEM OPTIONS | 25 |
| MARVEL J MAIN BOARD CONNECTION POINTS | 26 |
| PROGRAMMABLE PARAMETERS | 28 |

GENERAL PURPOSE

The Marvel “J” is an electronic programmable controller based on a double microprocessor design that is used to control United CoolAir provided air conditioners and air handling systems. The Marvel “J” (Figure 1 – Hardware / Architecture Layout) is made up of a microprocessor-based Main Board controller that is factory mounted and wired internal to the air handling system and a Terminal based wall mount control that must be field installed. The Marvel “J” system also contains optional sensors that must be field installed and wired back to the factory provided field interface terminal strips in the air handling system.

The Main Board is equipped with a set of plug in terminal block connectors used to connect the Main Board to the control devices (i.e. solenoid valves, compressor contactor(s), blower contactors, heater contactors). The program is stored on one (1) Megabyte of Flash Memory and the unit’s settings and control parameters are permanently stored (even in case of power failure). The Main Board can be linked to a Building Management System (BMS) via RS485 serial connection and customer provided communication protocol systems. The type of BMS system the Marvel “J” is connected to determines the type of optional communications board applied.

The microprocessor-based Terminal unit comes complete with LCD Display and Keypad for viewing and setting of the control parameters (set points, bands, and alarm thresholds, time clock settings for occupancy schedule and system run hours. etc.). The Terminal also allows viewing of the operating conditions, present settings, staging of system components, and system demands. Connection between the Marvel “J” “J’s” Terminal and Main Board is only required for viewing or changing of the operating conditions and set points.

STANDARD COMPONENTS

Standard Components

The following is a brief description of operation for standard and basic optional components:

- Time Clock with auto rechargeable battery backup.
- 7 Day Programmability for one Occupied Start point and one Unoccupied Stop point.
- A Proof of Airflow Switch which will shut down all modes of operation in case there is a loss of air flow.
- Drain Pan Overflow Switch provided to shut down compressors in the event of a blocked drain line or inoperable condensate pump.
- Dirty Air/Clogged Air Filter Switch provided to notify customers of a dirty air filter in the unit and a change of air filter(s) is required. This is only a notification (non-critical alarm) which does not shut down the blower or compressor(s).
- Programmable Alarm Thresholds for High and Low Temperature and Humidity Limits.
- Cooling is activated to satisfy the dehumidification demand and reduce the humidity level when it rises above the set point.

- If the temperature falls below the temperature set point during dehumidification and the unit has optional heaters, re-heat option required is then available to maintain the space temperature as close to the set point as possible.
- The compressor safety devices, sensors, and heaters are monitored by the Main Board for failure. When a failure occurs, the applicable system(s) are disabled.
- On a compressor failure of low or high pressure, the compressor is locked out from operating and another compressor(s) if available is substituted.

Basic Options

The following is a listing of optional components with a brief description of operation:

- Optional ON/OFF heating (electric, hot water coil, or steam coil) is sequenced on in stages based upon the demand for heating. Each stage of heat has programmable delay between stages so that two stages of heat do not turn on simultaneously.
- On a heater failure the heaters are locked out, but automatically reset when the safety resets. The display and alarm button will indicate an alarm occurred with the heating function.
- An optional humidifier is activated when the humidity falls below the humidity set point to satisfy the demand for humidification.
- Air Side Economizer is an option that can be provided for a means of using outdoor air to control the space being conditioned. It provides a more energy efficient method to cool the environment. This feature requires an outdoor temperature and humidity sensor that must be field installed.
- A Free Cooling Temperature Sensor can be provided for free cooling by means of a free-cool water coil. This sensor is factory mounted and wired into the Main Board.
- Networking of multiple systems is available and may be configured for stand alone in the network or Redundant operation.
- Redundant system operation of two units or multiple pairs of units with backup assist in the event of system failure is also available. Paired units may be set up to rotate at customer selected day intervals.
- Marvel “J” Main Boards may be networked to a Building Management System.

MARVEL “J” CONTROL OPERATION

Upon application of power from the main power supply, control voltage will be applied to the Marvel “J” Controller. The Marvel “J” Control is shipped from the factory in the OFF state. Once power is applied, a series of startup screens appear while the unit is initializing.

CAUTION: If power is disconnected from the unit while the Marvel “J” is in the ON state, the unit will automatically restart when power is reapplied. This means in the event of a power failure, the unit will automatically restart.

Pressing the ← (enter) button from the main screen will change the unit to “ON” or Run position. The supply air blower for the evaporator will start after a 15 second default time delay.

Fan Operation

The supply (evaporator) air blower operates based on the customer configuration (Continuous or On-Demand) which is set under the Factory Setup area. The default setting for the supply air blower from factory is Continuous. Upon initial power up, press the ← (enter) button for five seconds and “Off by Keypad” will change to “ON” in the lower line of text. The supply air blower will energize after a 15 second startup delay. If the On-Demand type of operation is desired, refer to the Factory Setup section under the System Delays screens. When On-Demand type of control is set up, the supply air blower will energize on a call for cooling, heating, humidification, or dehumidification.

Mechanical Cooling

System compressors are sequenced on in stages based on the demand for cooling. When the air temperature increases above the Room / Return air temperature set point, the cooling demand will start to increase. If the Room / Return air temperature increases above the Room / Return air temperature set point plus ½ of the band set point, the cooling demand will increase to 100% and Compressor 1 will energize. There is a programmable delay between each stage of compressor set from the factory for 60 seconds. If the cooling demand remains at 100% for more than each stage delay, remaining compressors (if available) are sequenced with a delay between each stage.

As the Room / Return air temperature falls below the Room / Return air temperature set point plus ½ of the band set point, the cooling demand will start to decrease. If available, compressor 2 will shut down as the cooling demand falls below 50%. As the cooling demand falls below 10%, Compressor 1 will shut down.

NOTE: When there is a demand for dehumidification, the dehumidification mode will override the cooling mode. This means even though the air temperature might be at or below the Room / Return air temperature set point, the compressors will operate to satisfy the dehumidification requirement. If the air temperature falls below the Room / Return air temperature set point during dehumidification, optional heating will be staged on for the reheat function to temper the air temperature and bring it back up to the Room / Return Air Temperature Set Point. Dehumidification will continue to operate until the requirement is satisfied.

Heating

System Heaters are sequenced on/off in stages based on the demand for heating. When the air temperature decreases below the Room / Return Air Temperature Set Point, the heating demand will start to increase. If the Room / Return Air Temperature decreases below the Room / Return Air Temperature Set Point minus ½ of the band set point, the heating demand will increase to 100% and Heater 1 will energize. There is a slight delay between each stage of heater. If the heating demand remains at 100%, remaining heat stages if available are sequenced on with a slight delay between each stage.

As the Room / Return air temperature increases above the Room / Return air temperature set point, the heating demand will start to decrease. Each stage will be shut down based on the amount of Heat Demand.

Reheat

If the Room/Return Air Humidity is above the Room/Return Humidity set point plus $\frac{1}{2}$ the band set point, the dehumidification demand will be 100% and the compressor(s) will energize for dehumidification.

If the Room/Return Air Temperature falls below the Room/Return Air Temperature Set Point minus $\frac{1}{2}$ the band set point during dehumidification, the heating demand will become 100%. The compressor(s) will continue operating and heating will stage on/off to satisfy the optional reheat function.

Airside Economizer Option

Airside Economizer is an optional feature that requires a factory provided (field installed) outdoor temperature and humidity sensor. If the Cooling Demand increases and the Outdoor Air Dew Point Temperature is less than the Room/Return Air Dew Point Temperature Set Point, and the Outdoor Air Temperature is below the Outdoor Air Temperature Set Point minus the Outdoor Air Temperature Band Set Point, the unit will perform Airside Economizer mode of operation. The amount of demand for Airside Economizer can be viewed by looking at the System Demands screen ECON xx%. When operating in airside economizer, the outdoor air dampers are modulated to the position that the ECON demand is calling for.

A minimum damper position setting is available within the advanced factory settings under the **Prg** button in the Factory Settings. Refer to the Economizer screen under the Advanced Factory Settings.

Airside Economizer will shut down when the Cooling Demand becomes 0% or if the Outdoor Air Temperature rises above the Outdoor Air Temperature Set Point plus Outdoor Air Temperature Band Set Point or when the Outdoor Air Enthalpy rises above the Room/Return Air Enthalpy.

The outdoor air enthalpy is calculated by the Outdoor Temperature and Humidity. The Room/Return Air enthalpy is calculated by the Room/Return Air Temperature and Humidity. If the Outdoor Air Enthalpy is lower than the Room/Return Air Enthalpy, then the Outdoor Air is better than the Room/Return Air.

Free Cooling Option

Free Cooling is an option available for a more energy efficient method of cooling when customers have cooling towers available and can provide an entering water temperature to the unit at times of 55°F or less. The Free Cool option requires a factory provided and mounted temperature sensor which is used to monitor the entering water temperature to the unit. If the entering water temperature is below the Free Cool Temperature Set Point minus the Free Cool Temperature Band Set Point, the Marvel "J" Main Board drives a water valve open to use the optional free cool water coil instead of mechanical cooling compressors.

Free Cool Mode will stop when the Cooling Demand is 0% or the entering water temperature increases above the Free Cool Temperature Set Point plus the Free Cool Temperature Band Set Point. If the water temperature increases above the Free Cool Temperature Band Set Point plus Free Cool Temperature Band Set Point and there is still a demand for cooling, the unit will revert back to mechanical cooling with compressors.

Modulating Hot Gas Bypass for Low/Partial Load Compressor Management Option

Modulating Hot Gas Bypass for Low/Light Load Compressor Management is an option used to false load the evaporator coil and compressor system during reduced loading conditions to the evaporator coil. Since the cooling demand has not been completely satisfied the compressor will continue to operate and the evaporator coil may start to freeze. The Marvel "J" Controller regulates the amount of hot gas applied to the evaporator coil to prevent the evaporator coil from freezing based on the cooling demand.

As the Cooling Demand increases, compressors are staged ON/OFF based on the Percentage of Demand for each Compressor and the overall Cooling Demand. As the Cooling Demand decreases to a point where the demand for cooling required is less than 50% demand and less than 100% demand of the first stage compressor, Hot Gas shall be modulated through the modulating Hot Gas Bypass Valve into the Evaporator Coil. If the cooling demand should then start to rise again to a point where the demand is greater than the 100% of cooling demand for the first stage compressor, the Modulating Hot Gas Bypass will modulate closed and if the demand becomes high enough, Compressor(s) 2 will stage on.

HARDWARE AND ARCHITECTURAL LAYOUT

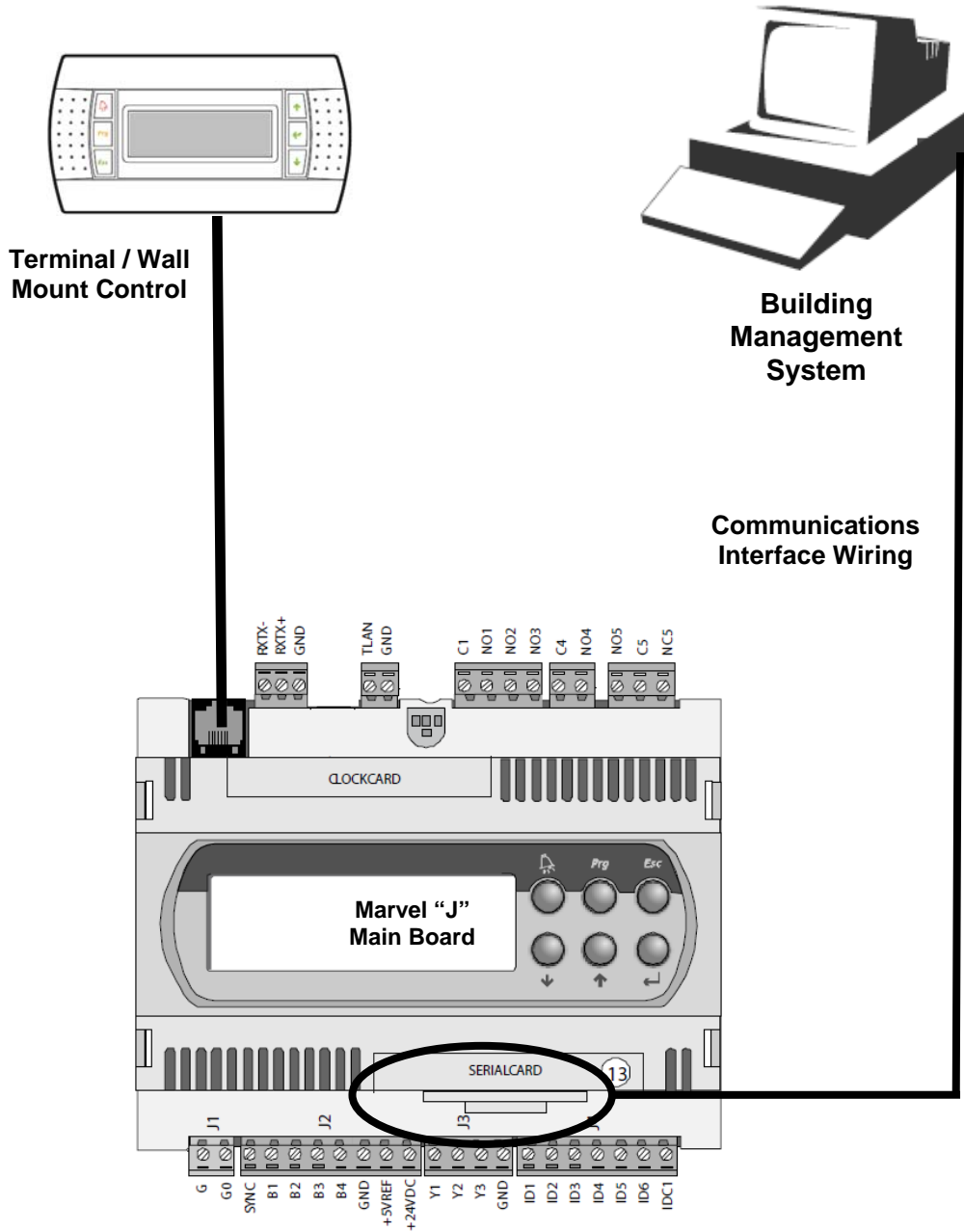

Figure 1 – Hardware/Architectural Layout
 (Shown with Wall Mount Terminal and optional On-Board Display)

MARVEL “J” MAIN BOARD

Figure 2 – Marvel “J” Main Board is the layout of the main control board. The reference designator J(xx) specifically lists the functions of each location on the board. These references are as follows:

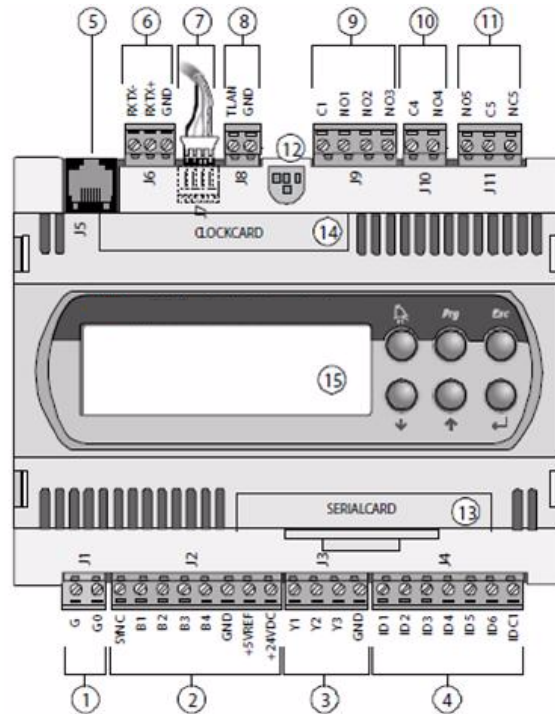

Figure 2 – Marvel “J” Main Board

J1 – Control Voltage connection terminals. 24 vac input required.

J2 – Analog Inputs used for sensor readings such as Space (Room or Return) Air Temperature, Space (Room or Return) Air Humidity.

J3 – Analog Outputs used for analog control of Modulating Heat, Hot Gas Bypass Valves, Airside Economizer Damper Actuators, Waterside Economizer Water Valves, Chilled Water Valves.

J4 – Digital Inputs used for Compressor High and Low Pressure Safety devices, Fire/Smoke Alarm indication and shut down, Dirty Air Filter, Condensate Drain Overflow, Heater High Limit, and/or Remote ON/OFF.

J5 – Marvel “J” wall terminal interface connection.

J6 – Communications interface wiring.

J8 – Communications interface for additional I/O Expansion Boards.

J9 – Digital Outputs used for Supply Air Blower ON/OFF, Compressor ON/OFF, and/or Humidifier.

J10 – Digital ON/OFF Output for Heater 1.

J11 – Digital ON/OFF Output for Heater 2 or Humidifier.

SENSOR INSTALLATION

Room Air Sensor Installation

Room Sensor Mounting

Install the Wall Mount Room Air Sensor interior to the space that is being conditioned. The sensor must be centrally located between all Return Air Grilles grilles. Do not install the sensor directly under any of the supply air grilles. Typically installation height is about 54"-60" above the floor. A template and mounting hardware are provided with the sensor. Once the position of installation is located, use the template and appropriate size drill bits to locate and drill the holes to install the sensor.

Room Sensor Wiring

Install a minimum 18-20 AWG 5-6 conductor shielded cable with drain wire and a minimum 300 volt insulation rating. Refer to Figure 3 – Space Air Sensor Wiring. **Caution: Sensor is polarity observant on the humidity side.** Terminate each conductor as follows:

- 1) Terminate TB2-NTC to one of the NTC terminals inside the sensor.
- 2) Terminate TB2-NTC to the other NTC terminal inside the sensor.
- 3) Terminate TB2-G+ to G+ inside the sensor.
- 4) Terminate TB2-M to M inside the sensor.
- 5) Terminate TB2-Hout to Hout inside the sensor.

Note: Connect the drain wire to units Ground Lug at the unit's electrical box only.

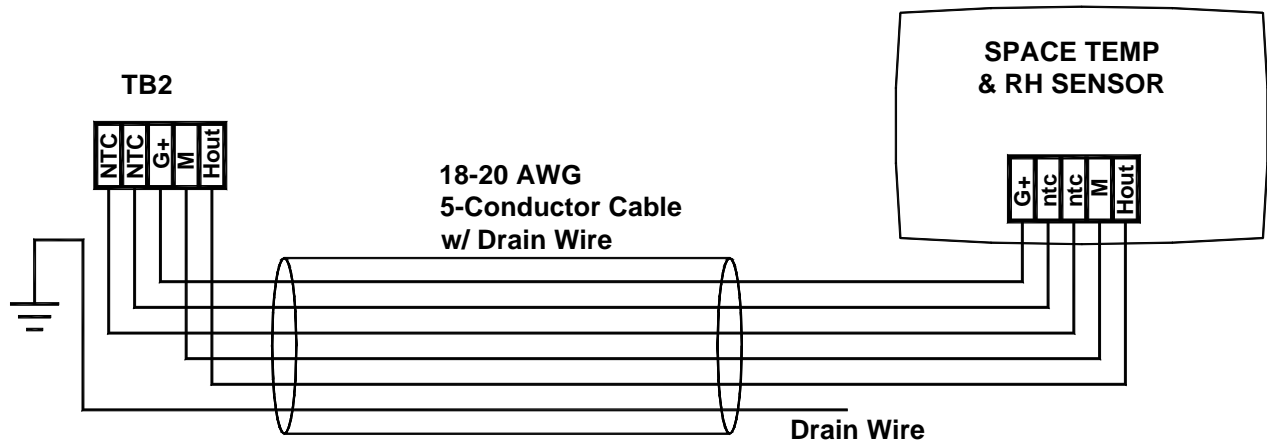
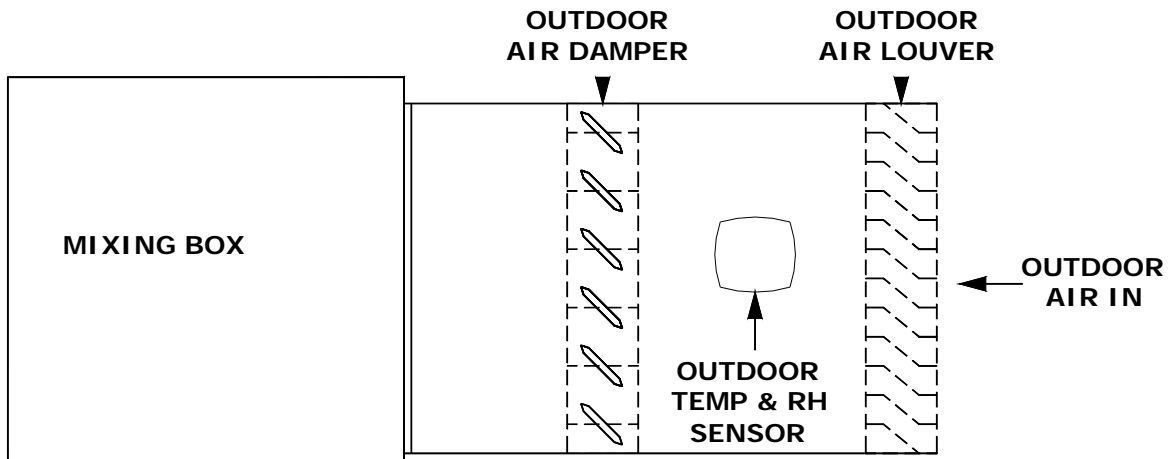

Figure 3 – Space Air Sensor Wiring

Outdoor Air Sensor Installation

Outdoor Sensor Mounting

Refer to Figure 4 – Outdoor Temp and Humidity Sensor mounting for an illustration of how to install the Duct Mount, Outdoor Air Temperature and Humidity sensor. Install the outdoor air sensor as close to the center of the duct as possible. It may be installed horizontally or vertically. It must be installed between the outdoor air louver and outdoor air damper. A template and mounting hardware are provided with the sensor. Once the position of installation is located, use the template and appropriate size drill bits to locate and drill the holes to install the sensor.



- NOTES:** 1. Outdoor Temp & RH Sensor is Factory Provided & Field Installed.
2. Outdoor Air Damper & Louver are Field Provided & Field Installed.

Figure 4 – Outdoor Temp and Humidity Sensor Mounting

Outdoor Sensor Wiring

Install a minimum 18-20 AWG 5 or 6 conductor shielded cable with drain wire and a minimum 300 volt insulation rating. Refer to Figure 5 – Outdoor Air Sensor Wiring. **Caution: Sensor polarity is important on the humidity side.** Terminate each conductor as follows:

- 1) Terminate TB3-NTC to one of the ntc terminals inside the sensor.
- 2) Terminate TB3-NTC to the other ntc terminal inside the sensor.
- 3) Terminate TB3-G+ to G+ inside the sensor.
- 4) Terminate TB3-M to M inside the sensor.
- 5) Terminate TB3-Hout to H_{out} inside the sensor.

Note: Connect the drain wire to units Ground Lug at the unit’s electrical box only.

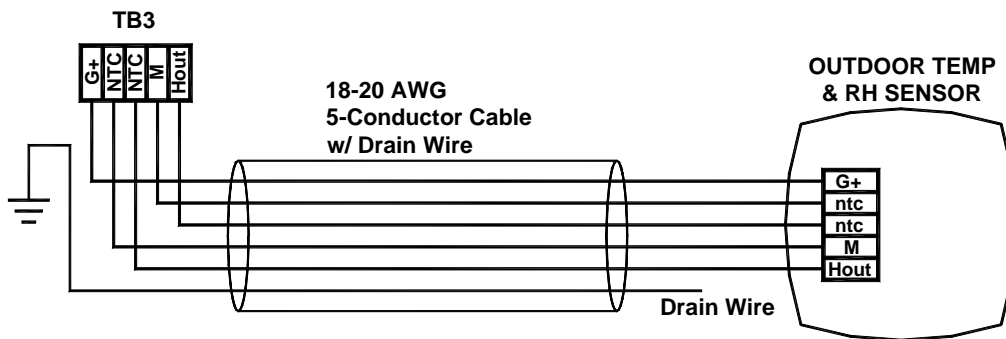





Figure 5 – Outdoor Air Sensor Wiring

MARVEL “J” TERMINAL (WALL CONTROL)

The Marvel “J” Terminal is complete with LCD Display and Keypad. The Terminal has LED indicators integral to the buttons. A description of each indicator light is discussed with the function of the each button starting on page 16. Use the table below for mounting distance and required wire gauge. Use a shielded cable is required when routing next to high voltage power wires.

| Distance | Wire Gauge |
|-----------------|------------|
| Up to 160 feet | 26 AWG |
| Up to 650 feet | 24 AWG |
| Up to 1500 feet | 20-22 AWG |

The Marvel “J” Terminal contains no sensors and does not need to be located in the building’s space that is being conditioned. See Figure 6 – Terminal below for reference. The Terminal is made up of the following components:

- A. External buttons *Prg*, *Esc*, , , and  or  (adjustment buttons) with integral LED indicators.
- B. A 22 character by 8 row LCD Display with English text for ease and understandability of adjustment.
- C. On board help system to navigate through the setup and changing of operating system parameters.

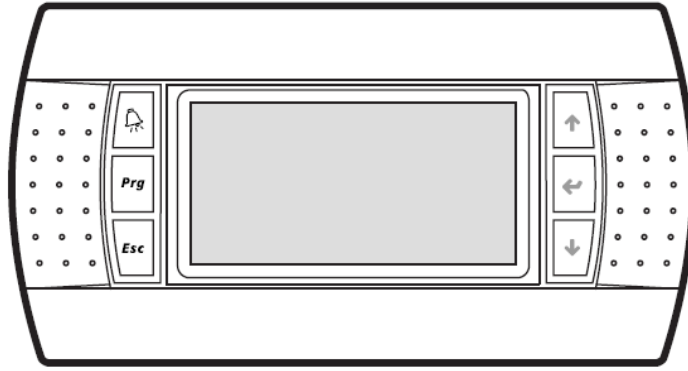

FIGURE – 6 Terminal (Wall Mount) Control DISPLAY DIMENSIONS

Refer to Figure 7 – Terminal Dimensions for dimensional data. Dimensions shown are in inches.

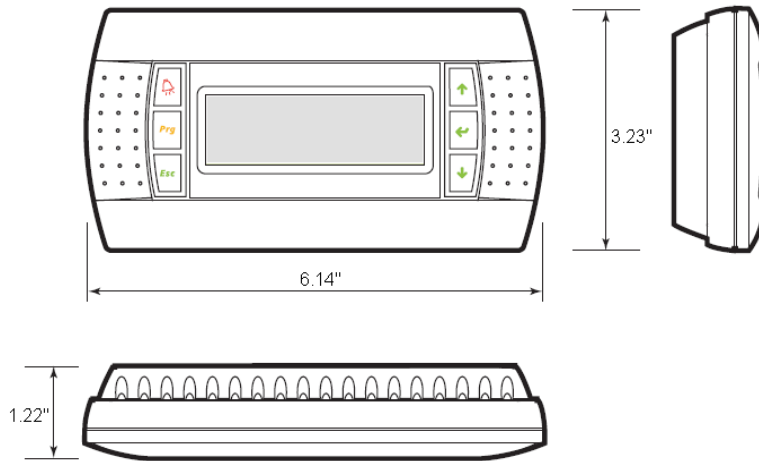

Figure 7 – Terminal Dimensions

MARVEL “J” DISPLAY (TERMINAL) – WALL MOUNTING

Refer to Figure 8 – Wall Mounting for instructions to mount the Terminal to a wall.

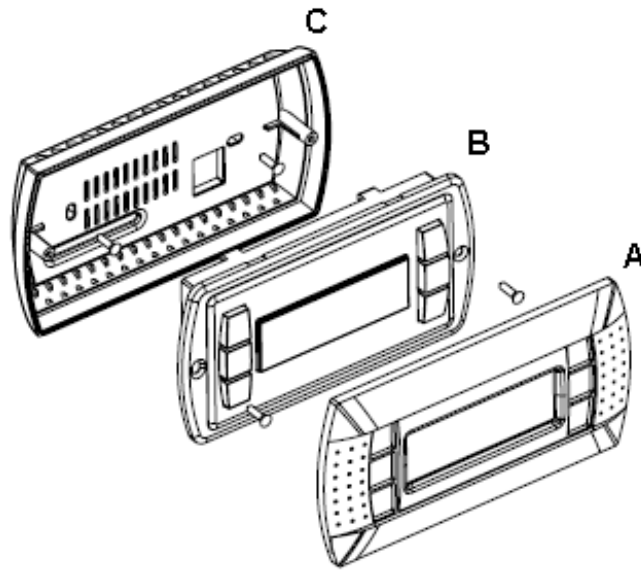

Figure 8 – Wall Mounting

Components of the Wall Controller:

- A. Faceplate
- B. Wall Controller
- C. Mounting Plate

For best results in mounting of the wall controller, obtain an single position Receptacle/Switch Electrical Box which typically measures approximately 3.75" high x 2.25" wide x 2.83" deep. Install the box sideways (90 degrees) internal to the wall from the original upright position. The box may be installed on metal or wood studded framing. Route the field provided connecting cable to the box.

1. Remove the Faceplate "A" from the Wall Controller.
2. Using a small straight screw driver, remove the two screws which secure the Wall Controller "B" to the Mounting Plate "C".
3. Route the connector/cable through the back of the Mounting Plate "C" then screw the mounting plate to the electrical box.
4. Plug the field provided Connecting Cable to the Wall Controller "B" then reinstall the Wall Controller "B" back onto the Mounting Plate "C".
5. Connect the field supplied standard phone cable into the coupler at the Main Board end.

CONNECTING CABLE

The Marvel "J" Terminal (Wall Control) connects to the Marvel "J" Main Board via a (field supplied) 6-conductor standard phone cord that must be coupled to a factory provided 4-foot phone cable. Pull a field supplied 6-conductor standard telephone cord or 6-conductor shielded cable from the Marvel "J" Main Board inside the unit's electrical control box to the location the Marvel "J" Terminal shall be installed. Refer to Figure 9 – Cable Information for additional details.

Maximum distances:

- 6-conductor phone cable (26 AWG) up to 160 feet.
- 6-conductor shielded 24 AWG wire up to 650 feet
- 6-conductor shielded 22 AWG wire up to 1500 feet

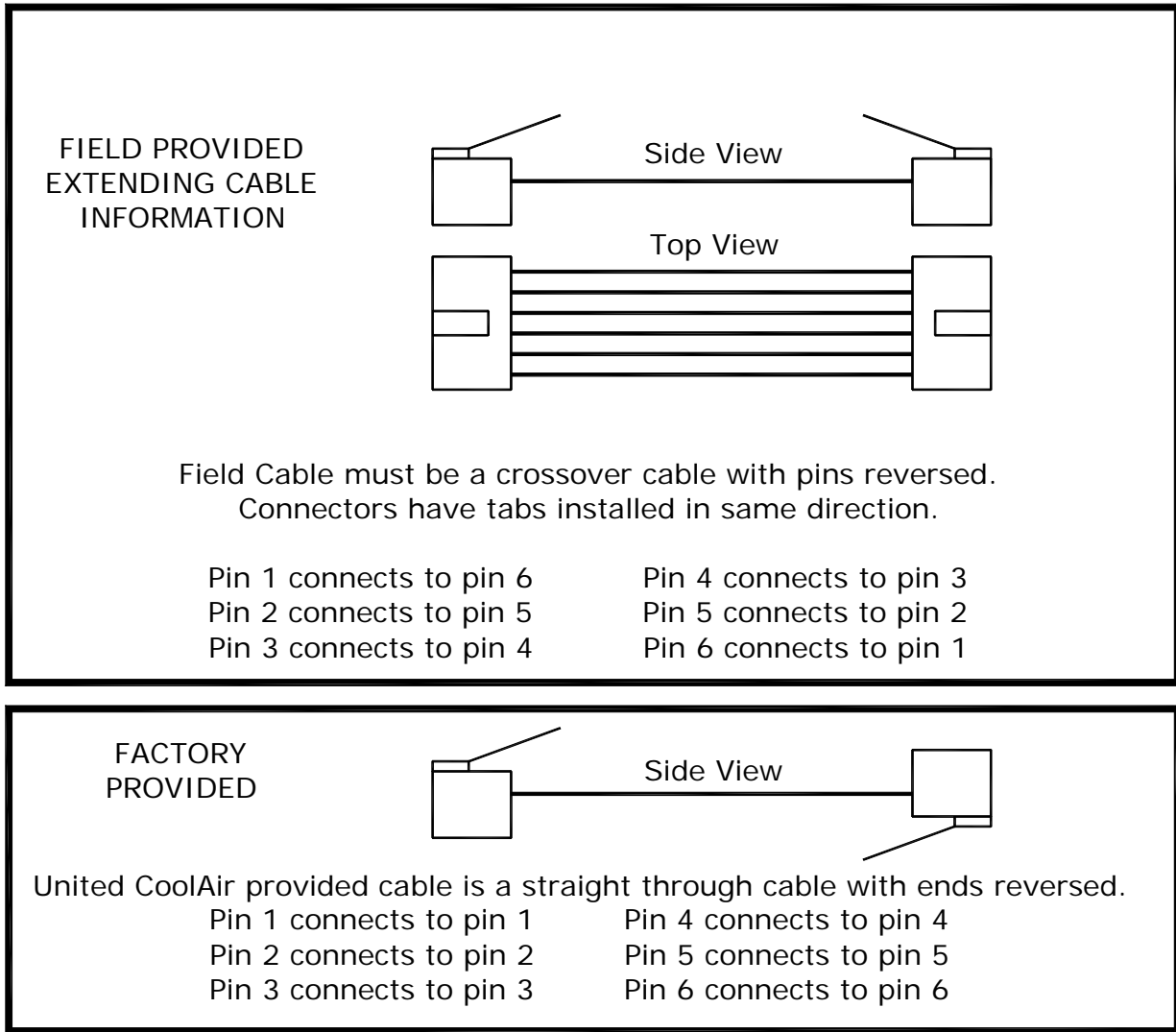

Figure 9 – Cable Information

A 4-foot piece of 6 conductor standard phone cable is provided with each unit. One end connects into an RJ12 Jack on the Marvel “J” Main Board. The other end of this phone cable connects into an RJ12 Coupler which is then connected to a field supplied cable to the location of Terminal installation.

CAUTION: This 4-foot cable is known as a Standard Cable. If the cable is placed flat on a table, the conductors look like they conduct straight through because one RJ12 connector is installed with the tab facing upward and the other RJ12 connector is installed with the tab facing downward. The difference is that the RJ12 connectors are installed rotated 180 degrees from one another. This makes this cable a standard/straight-through cable. One end is rotated 180 degrees from the other end thus reversing the conductors on the opposite end.

NOTE: DO NOT REPLACE THE 4-FOOT REVERSE PHONE CABLE as this cable has straight through conductors from the normal standard phone cable which reverses conductors. The Marvel “J” Terminal will not work if the connection is not correct and may damage the Marvel “J” Main Board or blow the fuse due to improper connections.

CONTROL BUTTONS

The Wall Controller has built in help menus to assist with the navigation through controller operation and unit setup. Follow the On Board Instructions to turn the unit ON and OFF and set the desired operating set points.

See Figure 10 – Control Buttons for reference.











| | |
|--|--|
|  ALARM BUTTON |  UP BUTTON |
|  PROGRAM BUTTON |  ENTER BUTTON |
|  ESCAPE BUTTON |  DOWN BUTTON |

Figure 10 – Control Buttons

ALARM BUTTON

The  button is used for viewing the present alarms with the system. During an alarm condition, the  button is illuminated a continuous Red. Depending on the type of alarm, the system may shut down or continue to operate. Some types of alarms are just simple faults known as indicators which are not harmful to the operation of the unit but may require attention in the near future. Pressing the  button will reveal what alarm caused the system to shut down. To reset an alarm, press the  button until the screen displays “NO MORE ALARMS; then to reset the alarm, simply press the  button again to reset the alarm.

NOTE: A High or Low Pressure Alarm can only be cleared once the Compressor has been re-enabled under the Enables sub-menu. If it is a high pressure alarm, make sure to reset the high pressure switch before re-enabling the alarm.

PROGRAM BUTTON

The **Prg** button is used to navigate directly to the page for direct access to the advance menu setup. Once on this page, customers have the option to enter the advance program or use the arrow up to change basic setup and operation parameters.

ESCAPE BUTTON

The escape button is used to go back to the Main Page and/or to a previous page depending on the page being displayed.

UP BUTTON

The up ↑ button is used to scroll upward through the pages/menus, increase a setting, or toggle a component ON/OFF.

 **ENTER BUTTON**

The ← button is used to turn the unit ON/OFF, move the cursor to the location of desired change, confirm temperature, humidity, and confirm selected components.

 **DOWN BUTTON**

The down ↓ button is used to scroll downward through the pages/menus, decrease a setting, or toggle a component ON/OFF.

STARTUP

Upon application of power the controller will display the following screen in Figure 11. This screen will automatically disappear once the controller has completely initialized.



Figure 11 – Initialization Screen

BASIC AND ADVANCED SETUPS

There are two specific methods that can be used to setup the system. These methods are BASIC SETUP and ADVANCED SETUP. As shown in Figures 6 and 10 previously, each of the buttons are used to access specific locations to Read or Change values (such as set points).

BASIC SETUP

The Basic Setup method allows customer to setup the control set points, (temperature, humidity, etc.), adjust the time and date, set time schedules. As shown below, Figure 12 – Home Page is the main home position page that appears continuously while the unit is on. In the event the user walks away from the wall controller while another screen other than the Home Page is displayed, the Home Page will reappear after five (5) minutes of inactive user interfacing.

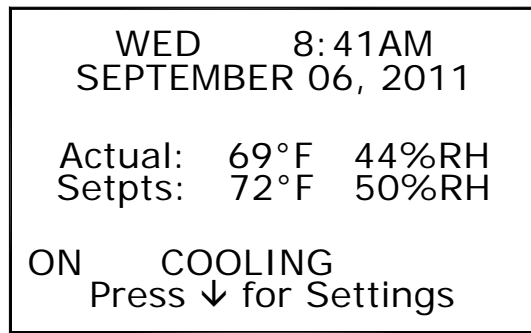
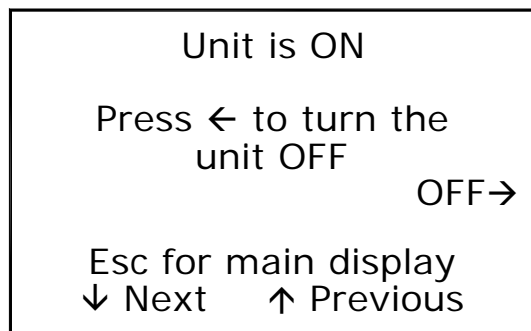

Figure 12 – Home Page

The Home Page displays the day of the week, time and date, actual temperature and humidity (if available) readings, as well as the temperature and humidity set points. The screen also gives a brief description of the operating status (system ON or OFF, Cooling or Heating, Humidification, Dehumidification, etc.).

To set up the unit for control of the space being conditioned, press the Down Arrow ↓ button to enter the Settings area. The screen below displays the status of the unit being ON or OFF. Follow the on screen command to turn the unit ON or OFF from this screen, simply press the Enter ← button. Then press the *Esc* or ↑ button to go back to the Previous/Home Page or press the ↓ button to go to the next screen in the Basic Setup loop.



The next screen allows for basic adjustment of the Temperature set point. It also allows for basic adjustment of the Humidity set point (if applicable). To change a set point, press the ← button to move the blinking cursor to the setting of the desired change. Press the ↑ or ↓ to adjust the setting then press the ← button to accept the change. Once complete, reposition the blinking cursor in the upper right corner of the display then press the ↓ button to go to the next screen in the basic setup or press the *Esc* button to go back to the Home Page

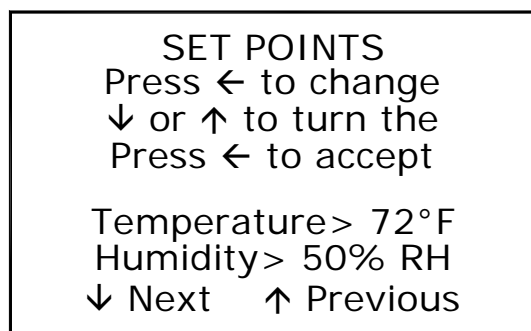

The next screen allows for adjustment of the Day and Time. Time is in AM-PM format. Note that this screen once the changes are accepted will not display the same as the Home Page. Once the Day and Time are adjusted, upon return to this screen the next time, it will again display THU at 00:00AM.

To change the day or time, press the ← button to move the blinking cursor to the setting of the desired change. Press the ↑ or ↓ to adjust the setting then press the ← button to accept the change. Once complete, reposition the blinking cursor in the upper right corner of the display then press the ↓ button to go to the next screen in the basic setup or press the *Esc* button to go back to the Home Page

SET DAY & TIME
Press ← to change
↓ or ↑ to turn the
Press ← to accept

Day>THU TIME>00:00AM

↓ Next ↑ Previous

The next screen allows for adjustment of the Date. Note that this screen once the changes are accepted will not display the same as the Home Page. Once the Date is adjusted, upon return to this screen the next time, it will again display 01/01/04.

To change the day or time, press the ← button to move the blinking cursor to the setting of the desired change. Press the ↑ or ↓ to adjust the setting then press the ← button to accept the change. Once complete, reposition the blinking cursor in the upper right corner of the display then press the ↓ button to go to the next screen in the basic setup or press the *Esc* button to go back to the Home Page

SET DATE
Press ← to change
↓ or ↑ to turn the
Press ← to accept

Date> 01/01/04

↓ Next ↑ Previous

The next screen allows for adjustment of the Occupancy Schedule. To change the schedule, press the ← button to enter the Occupied/Unoccupied Schedule setup. Press the ↑ or ↓ to adjust the setting then press the ← button to accept the change. Once complete, reposition the blinking cursor in the upper right corner of the display then press the ↓ button to go to the next screen in the basic setup or press the *Esc* button to go back to the Home Page.

Press ← for the
Schedule Settings
↓ Next ↑ Previous

The next two screens explain how to make the adjustments within the Schedule Setup area. Press the ↓ button to go to the next screen in the schedule setup area or press the *Esc* button to go back to exit and go to the Home Page.

Schedule Setting
Instructions
Press ↓ or ↑ to scroll
through the screens
Press ↓ for more
Press Esc to Exit

Schedule Setting
Instructions
Press ← to change
↓ or ↑ to turn the
Press ← to accept
Press ↓ to begin

To enable the schedule, press the ← button to move the cursor to the No and press the ↑ or ↓ button to change the field to Yes then press the ← button to accept the change. Then set the daylight savings time to Yes or No depending on your location of operation. If your particular time zone does not use daylight savings time at all, set the setting to No. Since most time zones do have daylight savings time, this setting is defaulted to Yes.

Enable Schedule
> No
Daylight
Savings Time?
> Yes

Set the minimum time the Night Set Back the unit should remain on when performing temperature or humidity control. If temperature control is desired set Temp Control to ON and set the desired High Temp and Low Temp settings. As long as the temperature remains between the High and Low Temperature settings while Unoccupied, the unit will not start to control the air temperature. If the actual air temperature is greater than the High Temperature set point, the unit will start and Cooling will be activated to cool the air temperature. If the actual air temperature is less than the Low Temperature set point, and the unit has optional heating, the unit will start and Heating will be activated to heat the air temperature.

U01 Unoccpied Control
Min Run Time > 10 min
Temp Control > OFF
High Temp > 090.0°F
Low Temp > 055.0°F

If optional humidity control is available and night set back control is desired for humidity, set the Hum Control to ON and set the desired High Hum and Low Hum settings. As long as the temperature remains between the High and Low Humidity settings while Unoccupied, the unit will not start to control the humidity. If the actual air humidity is greater than the High Humidity set point, the unit will start and Cooling will be activated to dehumidify the air. If the actual air humidity is less than the Low Humidity set point, and the unit has a humidifier the humidifier will be activated to humidify the air.

Unoccpied Control
Hum Control > OFF
High Hum > 065.0%
Low Hum > 035.0%

This screen allows for selection of which days customers would like to perform occupied and unoccupied control.

Select Days
SUN > NO
MON > NO
TUE > NO
WED > NO
THU > NO
FRI > NO
SAT > NO

This screen allows for changing of the occupied start times.

Occupied Start Time
SUN >06:00
MON >06:00
TUE >06:00
WED >06:00
THU >06:00
FRI >06:00
SAT >06:00

This screen allows for changing of the occupied end times.

Occupied End Time
SUN >18:00
MON >18:00
TUE >18:00
WED >18:00
THU >18:00
FRI >18:00
SAT >18:00

Press the **Esc** button to exit the Schedule Setup.

End of
Schedule Setup
Press Esc to Exit
↓ Next ↑ Previous

The advanced menu screen allows for access to the Advance Menu area. Under the Advance Menu area, the following Sub Menus are available for access. System Status, System Enables, System Set Points (includes control bands), Clock and Schedule Setup, System Run Hours, BMS Setup, Technician Menu, Factory Menu. Press the **←** button to enter the Advanced Menu area or the **Esc** button to exit to the home page.

Press ← for the
Advanced Menu
↓ Next ↑ Previous

A full help menu can be accessed from this screen which describes on screen commands. The bottom half of the Advance Menu system shows submenus which are available. Press the **↑** or **↓** buttons to navigate to the desired submenu. Press the enter button while the quad arrows are pointing at the specific item which is capitalized to enter a specific submenu.

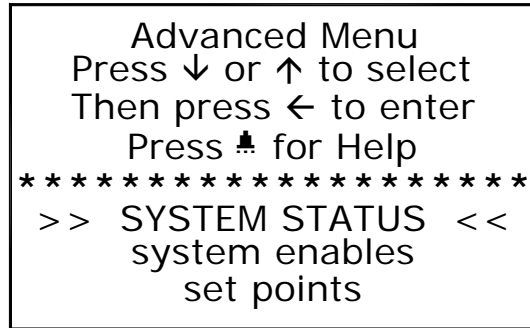

ADVANCED MENUS

The Advanced Menus shall be completed by December 2011. If additional details are required for the Advanced Menus area, please press the alarm button for Help or Contact United CoolAir Technical Support at (877) 905 – 1111.

INPUT WIRING

Digital Inputs

The digital inputs are syncing type. The IDC1 Terminal is common (24 VAC common / ground) of the controller. This termination is connected to every switching/safety device. If the terminals ID1-ID6 loose this ground connection, the controller will provide the appropriate alarm that is allocate to that specific digital input. Refer to Figure 13 – Digital Input Termination References for further details.

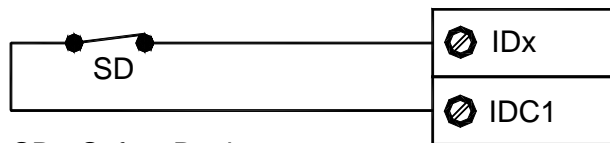

SD - Safety Device
 IDx - Digital Input
 IDC1 - Digital Input Common Connection

Figure 13 – Digital Input Termination References

Analog Inputs

A total of four Analog Inputs are provided for reading Space Air Temperature (Room or Return), Outdoor Air Temperature or Water Temperature, as well as Space (Room or Return) and Outdoor Air Humidity. Please refer to the electrical diagram(s) provided with each unit for field termination of each device being installed. These termination points are also defined by each electrical diagram provided with every unit.

Digital Outputs

There are 5 Digital Output Relays capable of handling up to 10 Amps Resistive at 1 Amp Inductive loading at 250 VAC. To power a control device (contactor, starter, solenoid coil, etc.) connect the neutral side of the 24 VAC power supply to the control device. Connect the hot side of the 24 VAC power supply through the common C(x) of the digital output relay as shown in Figure 14 – Digital Output Termination References.

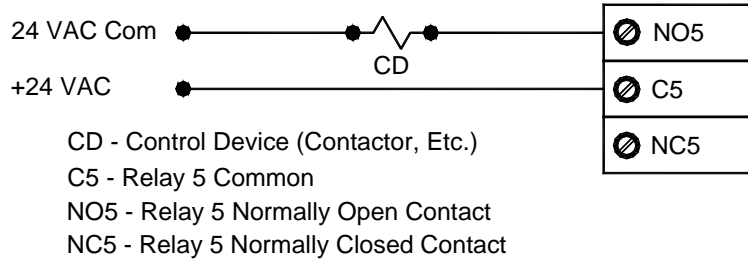

Figure 14 – Digital Output Termination References

Analog Outputs

There are 2 Analog Outputs each are capable of providing modulating output voltage of 0 – 10 VDC to control one of the following optional devices: Modulating Hot Gas Bypass, Modulating Heat, Room Pressure Dampers, Airside Economizer, or a Chilled Water Valve. The analogs outputs must be powered externally using 24 VAC. The neutral side of the 24 VAC power supply is connected to terminal VG0. The 24VAC hot side is connected to terminal VG1. Analog outputs 1 (Y1) and 2 (Y2) connect to the modulating input for the device being controlled. Refer to Figure 15 – Analog Output Termination References for connection details.

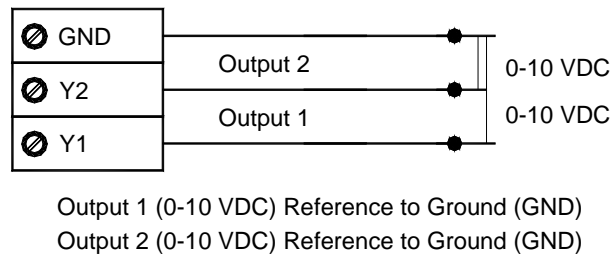

Figure 15 – Analog Output Termination References

REAL TIME CLOCK BOARD

The optional real time clock board Figure 16 is plugged into the connection point toward the center of the Main Board as shown in point 14, page 9. This board is required if the unit is to follow occupancy schedules or night set back schedules. The clock board is powered by a Lithium battery. All clock boards are installed at the factory but they are field replaceable if the clock fails. CAUTION: NEVER plug-in or remove the real time clock board when the control board is powered.

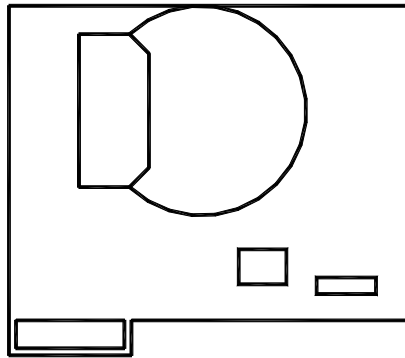

Figure 16 – Real Time Clock Board

BUILDING MANAGEMENT SYSTEMS (BMS SYSTEMS)

Several methods of supervisory systems may be used to communicate with the Marvel “J” Main Board which allow for monitoring of the systems readings, changing/offsetting of set points and remotely view alarm status. The following is a list of BMS Systems the Marvel “J” Control can interface with:

BACnet
ModBus
pCOWeb
LonWorks

MARVEL “J” MAIN BOARD CONNECTION POINTS

| Item # | Terminal | Description | Software Use |
|--------|----------|-------------------------------------|--|
| J1-1 | G | Power supply 24 VAC Input | |
| J1-2 | G0 | Power supply 24 VAC Common | |
| J2-2 | B1 | Analog Input 1 (0-1 Vdc or 0-20 mA) | Room or Return Air Humidity |
| J2-3 | B2 | Analog Input 2 (0-1 Vdc or 0-20 mA) | Outdoor Air Humidity |
| J2-4 | B3 | Analog Input 3 (NTC) | Room or Return Air Temperature |
| J2-5 | B4 | Analog Input 4 (NTC) | Outdoor Air Temperature or Water Temperature |
| J2-6 | GND | Reference Point | Analog Input Ground Reference |
| J2-7 | +5VREF | Power Supply | 0-5 Volt Radiometric Sensors |
| J2-8 | +24vdc | Power Supply | 0-20 and 4-20 milliamps sensors |
| J3-1 | Y1 | Analog Output 1 (0-10 Vdc) | Hot Gas, Economizer, Pressure, Humidifier, Chilled Water Modulating Heat |
| J3-2 | Y2 | Analog Output 2 (0-10 Vdc) | Hot Gas, Economizer, Pressure, Humidifier, Chilled Water Modulating Heat |
| J3-4 | GND | Reference Point | Analog Output Ground Reference |
| J4-1 | ID1 | Digital Input 1 | Airflow Loss or High Static Pressure |
| J4-2 | ID2 | Digital Input 2 | Smoke detector alarm |
| J4-3 | ID3 | Digital Input 3 | Dirty Filter |
| J4-4 | ID4 | Digital Input 4 | Drain Pan Overflow / Freeze Stat |
| J4-5 | ID5 | Digital Input 5 | Compressor 1 Low Pressure |

| Item # | Terminal | Description | Software Use |
|--------|----------|---|--|
| J4-6 | ID6 | Digital Input 6 | Compressor 1 Low Pressure |
| J4-7 | IDC1 | Common Input for Digital Inputs ID1-ID6 GND from Marvel J Board | |
| J5 | Terminal | 6-wire RJ11 telephone connection for Terminal | |
| J6-1 | RX-/TX- | Communications | Receive Data |
| J6-2 | RX+/TX+ | Communications | Transmit Data |
| J6-3 | GND | Communications | Ground Reference for Communications |
| J7 | | TLAN | Terminal Connector |
| J8-1 | TLAN | TLAN Network Connection | Expansion Board Communications |
| J8-2 | GND | TLAN Network Connection | Ground Reference for TLAN Expansion Board Communications |
| J9-1 | C1 | Common for Relay Outputs 1-3 | |
| J9-2 | NO1 | Relay 1 Normally Open Contact | Fan (Supply Air Blower) |
| J9-3 | NO2 | Relay 2 Normally Open Contact | Compressor 1 |
| J9-4 | NO3 | Relay 3 Normally Open Contact | Compressor 2 |
| J10-1 | C4 | Common for Relay Output 4 | |
| J10-2 | NO4 | Relay 4 Normally Open Contact | Heater 1 |
| J11-1 | NO5 | Relay 5 Normally Open Contact | Heater 2 |
| J11-1 | C5 | Common for Relay Output 5 | |
| J11-3 | NC5 | Relay 5 Normally Closed Contact | |

PROGRAMMABLE PARAMETERS

| Parameter/Description | Default | Lower/Upper Limits | Unit of Measure |
|--|---------|--------------------|-----------------|
| Room / Return Temperature Setting | 72 | 50/90 | °F |
| Room / Return Temperature Band | 5 | 0-99 | °F |
| Room / Return Humidity Set point | 50 | 35-65 | % RH |
| Room / Return Humidity Band | 10 | 0-99 | % |
| Discharge Temperature Set Point | 55 | 50-70 | °F |
| Discharge Temperature Band | 10 | 5-10 | °F |
| Room / Return Hi / Low Temperature Alarm | 80/60 | 50-120 | °F |
| Room Hi Low Humidity Alarm | 65/35 | 0/100 | % RH |
| Enable Night Setback | OFF | On/Off | |
| Night Minimum ON | 300 | 0-999 | Seconds |
| Night Setback Hi / Low Temp | 90/55 | 50-120 | °F |
| Night Setback Hi / Low Humidity | 65/35 | 0-100 | % RH |
| Occupied / Unoccupied Times | 6/18:00 | 0:00-23:59 | Hours/Minutes |
| Supervisor Unit Identification | 1 | 1-200 | |
| Supervisor Baud Rate | 19200 | 1200-19200 | Baud |