

# UNITED COOLAIR CORPORATION

## MARVEL HVAC MICROPROCESSOR CONTROLLER INSTALLATION AND OPERATING MANUAL

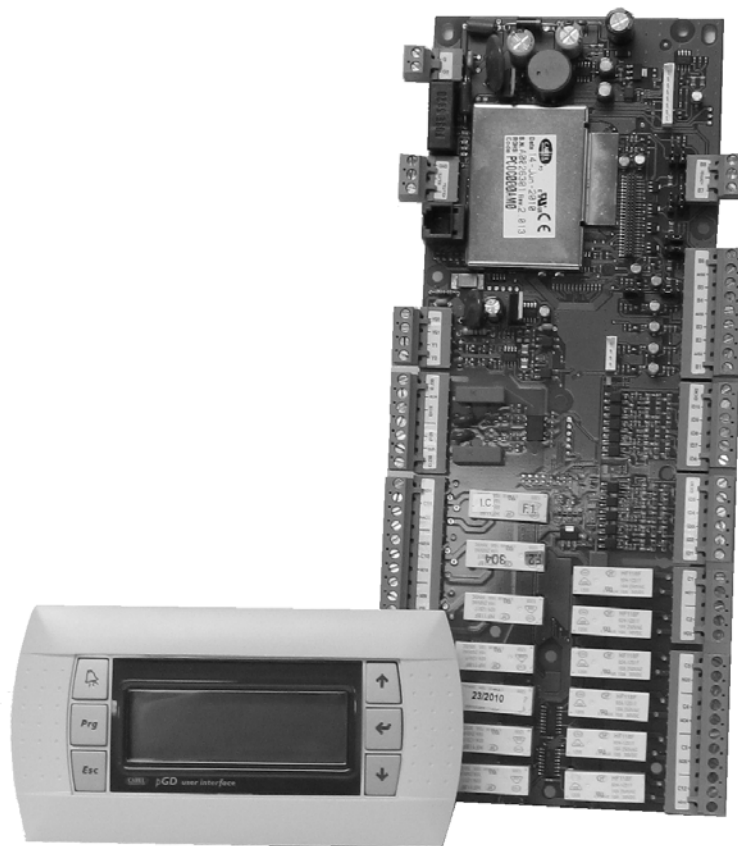

491 E. PRINCESS ST. YORK, PA 17405

PH: (877) 905 – 1111 FAX: (717) 854 – 4462

## TABLE OF CONTENTS

GENERAL PURPOSE .....	3
STANDARD AND OPTIONAL COMPONENT INFORMATION .....	3
HARDWARE AND ARCHITECTURAL LAYOUT .....	5
MARVEL MAIN BOARD .....	6
MARVEL TERMINAL (WALL CONTROL) .....	7
CONTROL BUTTONS .....	7
ALARM BUTTON .....	8
PRG BUTTON .....	8
ESC BUTTON .....	8
UP BUTTON .....	8
ENTER BUTTON .....	8
DOWN BUTTON .....	8
PROGRAMMING AND OPERATING SCREENS .....	8
LCD DISPLAY .....	9
DISPLAY DIMENSIONS .....	9
WALL MOUNTING .....	10
CONNECTING CABLE .....	11
SENSOR INSTALLATION .....	12
MARVEL CONTROL OPERATION .....	15
MARVEL TERMINAL KEYPAD AND DISPLAY OPERATION .....	19
ALARM BUTTON (ALARMS AND RESETTING) .....	19
MAIN STATUS SCREENS .....	25
SETPOINTS .....	27
TIME CLOCK SETTINGS .....	29
SYSTEM ENABLES .....	31
EQUIPMENT RUN HOURS .....	33
ANALOG/DIGITAL INPUTS/OUTPUTS .....	34
PRG & Esc .....	38
MARVEL MAIN BOARD LAYOUT .....	51
INPUT WIRING .....	53
OPTIONAL BOARDS .....	54
BUILDING MANAGEMENT SYSTEMS (BMS SYSTEMS) .....	55
SYSTEM NETWORKING .....	55
MARVEL MAIN BOARD CONNECTION POINTS .....	58
PROGRAMMABLE PARAMETERS .....	63

## GENERAL PURPOSE

The MARVEL is an electronic programmable controller based on a double microprocessor design that is used to control United CoolAir provided air conditioners and air handling systems. The MARVEL (Figure 1 – Hardware / Architecture Layout) is made up of a microprocessor-based Main Board controller that is factory mounted and wired internal to the air handling system and a Terminal based wall mount control that must be field installed. The MARVEL system also contains optional sensors that must be field installed and wired back to the factory provided field interface terminal strips in the air handling system.

The Main Board is equipped with a set of plug in terminal block connectors used to connect the Main Board to the control devices (i.e. solenoid valves, compressor contactor(s), blower contactors, heater contactors). The program is stored on one (1) Megabyte of Flash Memory and the unit's settings and control parameters are permanently stored (even in case of power failure). The software program is designed for "smart control", which automatically calculates projected changes based upon present readings over time intervals and tries to predict the proper staging to maintain set point within the space. The Main Board can be linked to a Supervisory / Tele-Maintenance system via RS485 serial connection and customer provided communication protocol systems.

The microprocessor-based Terminal unit comes complete with LCD Display and Keypad for viewing and setting of the control parameters (set points, bands, and alarm thresholds, system run hours. etc.). The Terminal also allows viewing of the operating parameters, staging of system components, and system demands. Connection between the MARVEL's Terminal and Main Board is only required for viewing or changing of the operating conditions and set points.

## STANDARD AND OPTIONAL COMPONENT INFORMATION

### Standard and Basic Optional Components

The following is a brief description of operation for standard and basic optional components:

- Optional ON/OFF (electric, hot water coil, or steam coil) are sequenced on in stages based upon the demand for heating. Each stage of heat has programmable delay between stages so the two stages of heat do not turn on at the same time.
- An optional humidifier is activated when the humidity falls below the humidity set point to satisfy the demand for humidification.
- Cooling is activated to satisfy the dehumidification demand and reduce the humidity level when it rises above the set point.
- If the temperature falls below the temperature set point during dehumidification, the re-heat option is energized at the same time by turning on stages of heat to maintain the space temperature as close to the set point as possible.
- The compressor safety devices, sensors, and heaters are monitored by the Main Board for failure. When a failure occurs, the applicable system(s) are disabled.
- On a compressor failure of low or high pressure, the compressor is locked out from operating and another compressor(s) if available is substituted.

- An Air Switch has been incorporated to turn off cooling, heating, dehumidification, and humidification in the event of a loss of air flow due to a broken v-belt or other means.
- On a heater failure the heaters are locked out, but automatically reset when the safety resets. The display and alarm button will indicate an alarm occurred with the heating function.

### **Additional Optional Components**

The following is a listing of optional components with a brief description of operation:

- Air Side Economizer is an option that can be provided for a means of using outdoor air to control the space being conditioned. It provides a more energy efficient way to cool the environment. This feature requires an outdoor temperature and humidity sensor that must be field installed.
- A Free Cooling Temperature Sensor can be provided for free cooling by means of a free-cool water coil. This sensor is factory mounted and wired into the Main Board.
- A Room Pressure Sensor can be provided to control dampers to satisfy room pressure requirements for isolation rooms or clean rooms
- Electronic Modulating Hot Gas Bypass Valves can be provided for capacity control/Discharge Air Temperature control. These valves are factory installed and wired into the Marvel Main Board.
- Networking of multiple systems is available and may be configured for stand alone in the network or Redundant operation.
- Redundant system operation of two units or multiple pairs of units with backup assist in the event of system failure is also available. Paired units may be set up to rotate at customer selected day intervals.
- Marvel Main Boards may be networked to a Building Management System.

# HARDWARE AND ARCHITECTURAL LAYOUT

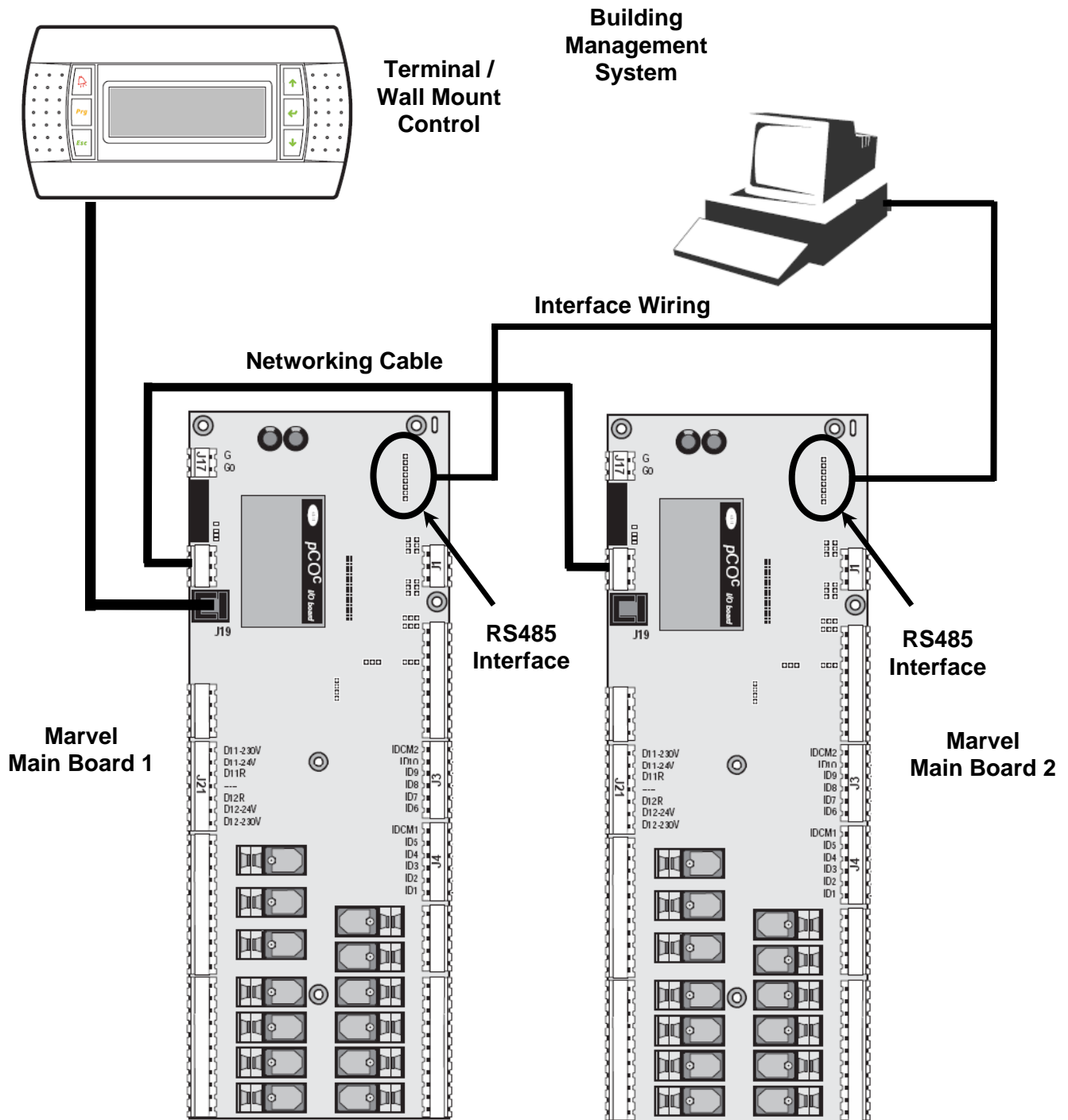
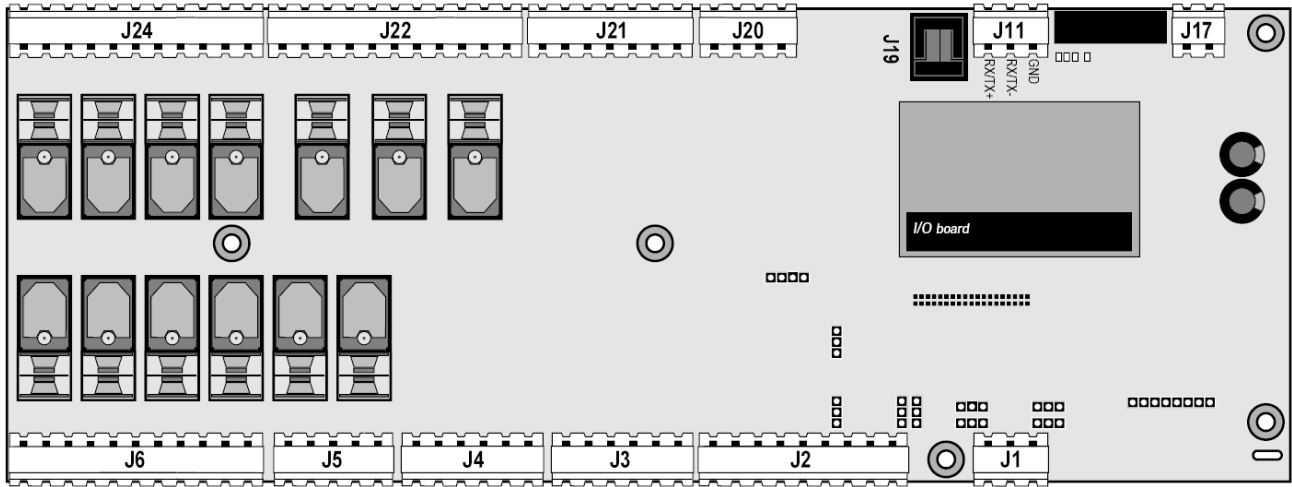

FIGURE 1 – HARDWARE / ARCHITECTURE LAYOUT

## MARVEL MAIN BOARD

Figure 2 – Marvel Main Board is the layout of the main control board. The reference designator Jxx specifically lists the functions of each location on the board. These references are as follows:



**Figure 2 – Marvel Main Board**

J1 – Analog Inputs used for sensor readings such as VFD feed back position signal from a VFD and Outdoor Air Humidity readings.

J2 – More Analog Inputs used for sensor readings such as Room/Return Air Temperature, Discharge Air Temperature, Free Cool Temperature, Outdoor Temperature, Duct/Room Pressure, Room/Return Air Humidity.

J3 – Digital Inputs used for Compressor High and Low Pressure Safety devices, Fire/Smoke Alarm indication and shut down, Remote ON/OFF.

J4 – Digital Inputs used for Compressor High and Low Pressure Safety devices, High Limit Heat Alarm indication and shut down, Loss of Air Flow, Dirty Air Filter notification.

J5 – Digital Outputs used for Compressor ON/OFF and Supply Air Blower ON/OFF.

J6 – Digital Outputs used for Compressor ON/OFF, Heater ON/OFF, and optional Water Pump ON/OFF control.

J24 – Digital Outputs used for optional devices such as Compressor 3 ON/OFF, Remote Alarm Contacts, Outdoor Air Dampers, Compressor 1 and 2 Unloader Control, and Fan Speed Control.

J22 – Digital Outputs used for Condenser ON/OFF and optional devices such as Remote Alarm Contacts, Heat Stage 4, Free Cool ON/OFF.

J21 – Digital Inputs used for Compressor 3 High/Low Pressure Safety devices.

J20 – Analog Outputs used for analog control of Modulating Heat, Hot Gas Bypass Valves, Economizer Damper Actuators, Chilled Water Valves, and Room/Duct Pressure Control Actuators.





J11 – Networking interface connections. Used for connection of multiple controllers in a network.

J17 – Control Voltage connection terminals. 24 vac input required.

## MARVEL TERMINAL (WALL CONTROL)

The Marvel Terminal is complete with LCD Display and Keypad. The Terminal has LED indicators integral to the buttons. A description of each indicator light is discussed with the function of the each button starting on page 8.

The Marvel Terminal contains no sensors and does not need to be located in the building's space that is being conditioned. The Terminal can be mounted up to 1500 feet from the equipment. See Figure 3 – Terminal below for reference. The Terminal is made up of the following components:



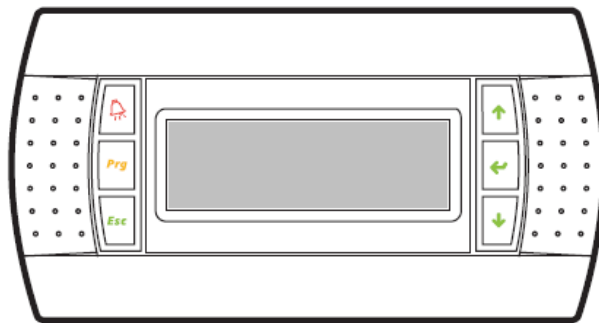



- A. External buttons *Prg*, *Esc*, , , and  or  (adjustment buttons) with integral LED indicators.
- B. Submenus include SETPOINTS, Time Clock Settings, EQUIPMENT RUN HOURS, SYSTEM ENABLES, and ANALOG DIGITAL INPUT SETUP.
- C. A 20 character by 4 row LCD Display with English text for ease and understandability of adjustment.



**FIGURE – 3 Terminal (Wall Mount) Control**

## CONTROL BUTTONS





See Figure 4 – Control Buttons for reference.

 ALARM BUTTON	 UP BUTTON
 PROGRAM BUTTON	 ENTER BUTTON
 ESCAPE BUTTON	 DOWN BUTTON

**Figure 4 – Control Buttons**



## ALARM BUTTON

The  button is used for viewing the present alarms with the system. During an alarm condition, the  button is illuminated a continuous Red. Depending on the type of alarm, the system may shut down or continue to operate. Some types of alarms are just simple faults known as indicators which are not harmful to the operation of the unit but may require attention in the near future. Pressing the  button will reveal what alarm caused the system to shut down. To reset an alarm, press the  button until the screen displays “NO MORE ALARMS; To reset the alarm, simply press the  button again to reset the alarm.



## PROGRAM BUTTON

The **Prg** button is used to program the system’s set points, alarm thresholds, adjust time clock settings, adjust sensor calibration, enable system operation, view run hours, set occupied/unoccupied schedules, and much more.



## ESCAPE BUTTON

The escape button is used to go back to the home page of the Status Screens.



## UP BUTTON

The up button is used to scroll upward through the pages/menus, increase a setting, or toggle a component ON/OFF.



## ENTER BUTTON

The  button is used to confirm temperature, humidity, or pressure settings, and confirm selected components. It is also used to clear alarms once the alarm is viewed.



## DOWN BUTTON

The down button is used to decrease a setting or toggle a component ON/OFF.

## PROGRAMMING AND OPERATING SCREENS

As shown in Figure 4 previous, each of the buttons are used to access specific locations to Read or Change (such as set point) values. Below is a list of the menus that are accessible from the wall mount controller. By pressing the **Prg** button multiple times, the following menu will appear:

1. **SET POINTS menu**– Used for changing temperature and humidity settings. It is also used to set temperature high and low alarm set points as well as humidity high and low alarm set points. If customers have the pressure control option, settings will also appear to adjust duct or room pressure.
2. **TIME CLOCK SETTINGS menu** – Used for changing the Time Clock Readings to the current Time and Date. This menu is also used for setup of Daylight Savings Time based on region and enabling of the Night Set Back Function. Once the Night Set Back Function is enabled, the type of control (Temp/Humidity Setback) is enabled and Set Points for Temperature and Humidity Setback Control shall appear as well as the day of the week to enable Night Set Back and time of day for occupied and unoccupied period.

3. **SYSTEM ENABLES menu** – This sub-menu allows for re-enabling of system functions (System ON/OFF, Humidification/Dehumidification, Compressors, Heaters, ON/OFF and Modulating Reheat, etc.) after an alarm condition has occurred.
4. **EQUIPMENT RUN HOURS menu**– Displays the operational run hours of system components such as Fan, Humidifier, Compressors, Heaters, etc.).
5. **ANALOG/DIGITAL INPUTS/OUTPUTS menu** – This sub-menu is used to calibrate sensors and alarm input setup settings.
6. **PRG & ESC (Factory Setup menu)** – Used for changing the Factory Default System settings. It is used to change control functions with their equipment.

## LCD DISPLAY

The Terminal provides four or eight lines of twenty to twenty-two characters per line LCD Display. The character is 5 mm in height. See Figure 5 – LCD Display.



**Figure 5 – LCD Display**

## DISPLAY DIMENSIONS

Refer to Figure 6 – Terminal Dimensions for dimensional data. Dimensions shown are in inches.

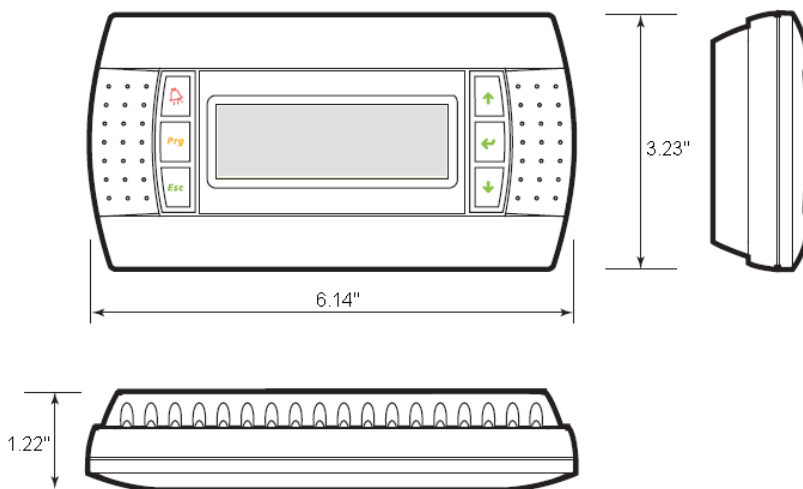

**Figure 6 – Terminal Dimensions**

## MARVEL DISPLAY (TERMINAL) – WALL MOUNTING

Refer to Figure 7 – Wall Mounting for instructions to mount the Terminal to a wall.

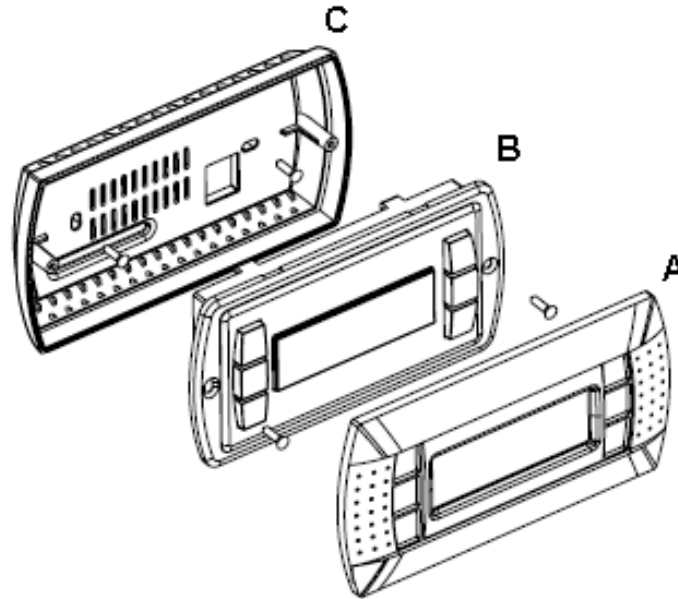

**Figure 7 – Wall Mounting**

Components of the Wall Controller:

- A. Faceplate
- B. Wall Controller
- C. Mounting Plate

For best results in mounting of the wall controller, obtain an single position Receptacle/Switch Electrical Box which typically measures approximately 3.75" high x 2.25" wide x 2.83" deep. Install the box sideways (90 degrees) internal to the wall from the original upright position. The box may be installed on metal or wood studded framing. Route the field provided connecting cable to the box.

1. Remove the Faceplate "A" from the Wall Controller.
2. Using a small straight screw driver, remove the two screws which secure the Wall Controller "B" to the Mounting Plate "C".
3. Route the connector/cable through the back of the Mounting Plate "C" then screw the mounting plate to the electrical box.
4. Plug the field provided Connecting Cable to the Wall Controller "B" then reinstall the Wall Controller "B" back onto the Mounting Plate "C".
5. Connect the field supplied standard phone cable into the coupler at the Main Board end.

## CONNECTING CABLE

The Marvel Terminal (Wall Control) connects to the Marvel Main Board by a (field supplied) 6-conductor standard phone cord that must be coupled to a factory provided 4-foot Reverse phone cable. Pull a field supplied 6-conductor standard telephone cord from the Marvel Main Board at the evaporator's electrical control box to the location the Marvel Terminal shall be installed. Refer to Figure 8 – Cable Information for additional details.

A 4-foot piece of 6 conductor reversed phone cable is provided with each unit. One end connects into an RJ12 Jack on the Marvel Main Board. The other end of this phone cable connects into an RJ12 Coupler and must be field connected on the opposite end using a standard phone cable.

**CAUTION:** This 4-foot cable is known as a Reversing Cable. If the cable is placed flat on a table, the conductors look like they conduct straight through. The difference is that the RJ12 connectors are installed rotated 180 degrees from one another. This makes this cable a reverse or crossover type cable. One end is rotated 180 degrees from the other end thus reversing the conductors on the opposite end.

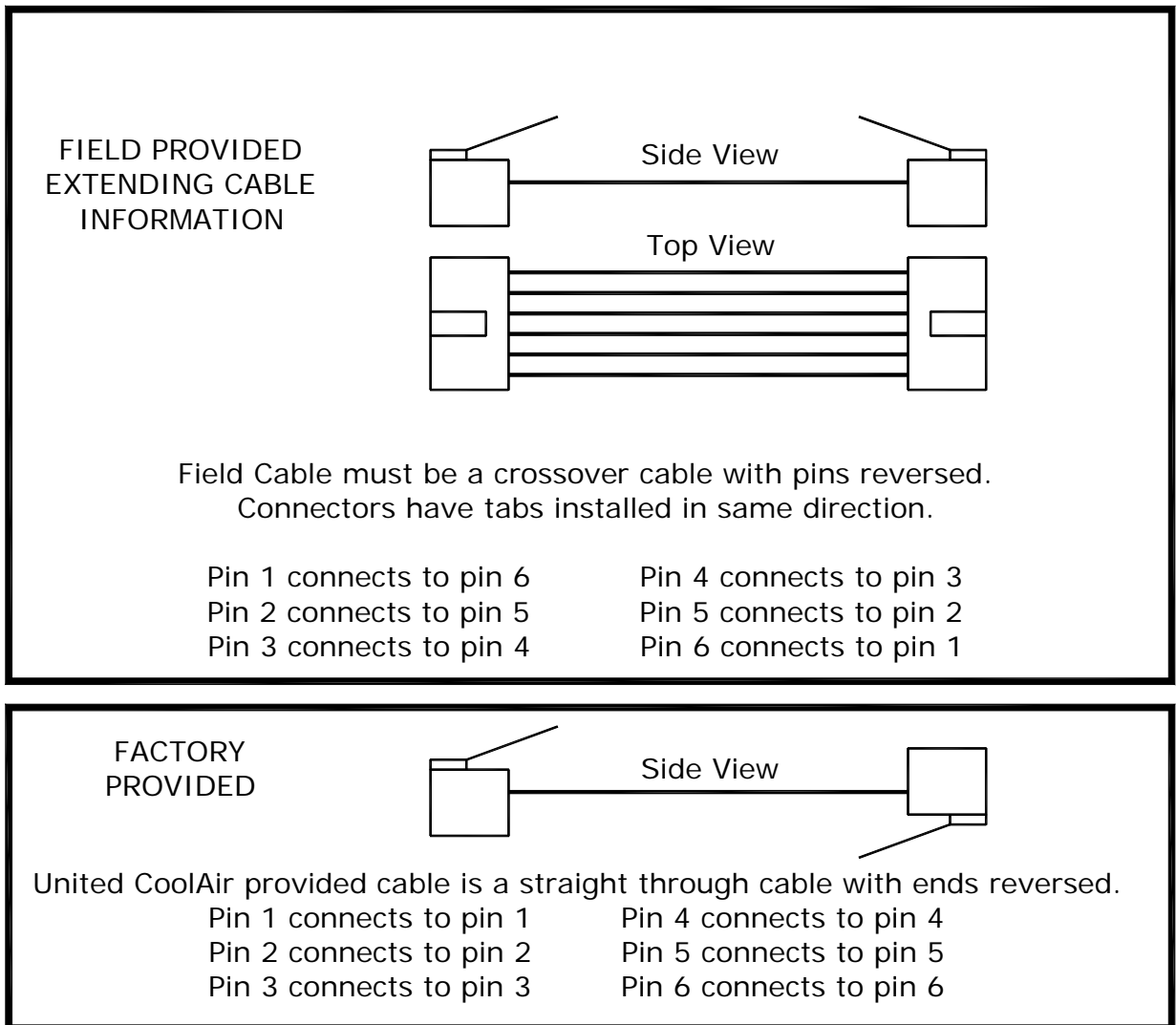

**Figure 8 – Cable Information**

**NOTE: DO NOT REPLACE THE 4-FOOT REVERSE PHONE CABLE** as this cable has straight through conductors from the normal standard phone cable which reverses conductors. The Marvel Terminal will not work if the connection is not correct and may damage the Marvel Main Board or blow the fuse due to improper connections.

## SENSOR INSTALLATION

### Supply Air Temperature Sensor (SATS) Installation

There are two types of supply air temperature sensors available.

1. Factory installed supply air temperature sensor is bulb type sensor located at the supply air blower.
2. Factory provided, field installed is a duct mount type supply air temperature sensor.

#### Mounting – Duct Mount Type

The Supply Air Temperature Sensor must be field installed in the supply air ducting. Install the supply sensor as close to the center of the duct as possible. It may be installed horizontally or vertically. Install the sensor at a distance of 6 to 10 times the diameter of the blower wheel from the discharge of the blower housing. A template and mounting hardware are provided with the sensor. Once the location of installation is selected, use the template and appropriate size drill bits to drill the mounting holes for installation of the sensor. Refer to Figure 9 – Supply Air Temperature Sensor Mounting.

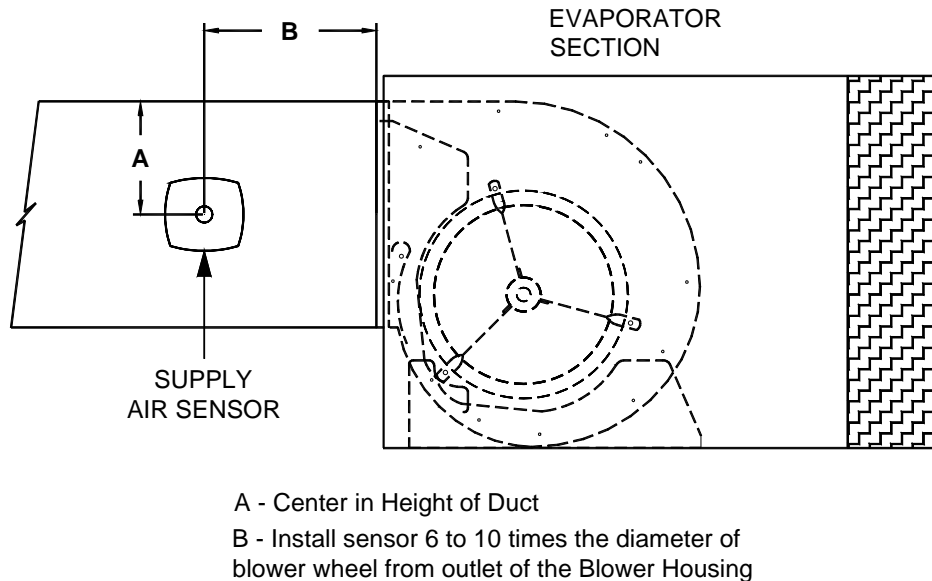

**Figure 9 – Supply Air Temperature Sensor Mounting**

#### Wiring

Install a minimum 18-20 AWG 2-3 conductor shielded cable with drain wire and a minimum 300 volt insulation rating. Refer to Figure 10 – Supply Air Sensor Wiring. Terminate each conductor as follows:

- 1) Terminate TB4-NTC to one of the NTC terminals inside the sensor.
- 2) Terminate TB4-NTC to the other NTC terminal inside the sensor.

**Note: Connect the drain wire to units Ground Lug at the unit's electrical box only.**

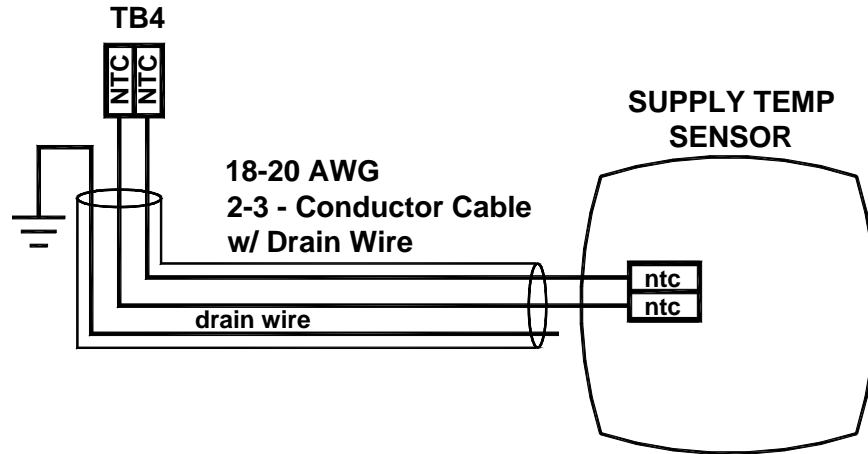

**Figure 10 – Supply Temp Sensor Wiring**

## **Room Air Sensor Installation**

### **Mounting**

Install the Wall Mount Room Air Sensor interior to the space that is being conditioned. The sensor must be centrally located between all Return Air Grilles grilles. Do not install the sensor directly under any of the supply air grilles. Typically installation height is about 54"-60" above the floor. A template and mounting hardware are provided with the sensor. Once the position of installation is located, use the template and appropriate size drill bits to locate and drill the holes to install the sensor.

### **Wiring**

Install a minimum 18-20 AWG 5-6 conductor shielded cable with drain wire and a minimum 300 volt insulation rating. Refer to Figure 11 – Space Air Sensor Wiring. **Caution: Sensor is polarity observant on the humidity side.** Terminate each conductor as follows:

- 1) Terminate TB2-NTC to one of the NTC terminals inside the sensor.
- 2) Terminate TB2-NTC to the other NTC terminal inside the sensor.
- 3) Terminate TB2-G+ to G+ inside the sensor.
- 4) Terminate TB2-M to M inside the sensor.
- 5) Terminate TB2-Hout to Hout inside the sensor.

**Note: Connect the drain wire to units Ground Lug at the unit's electrical box only.**

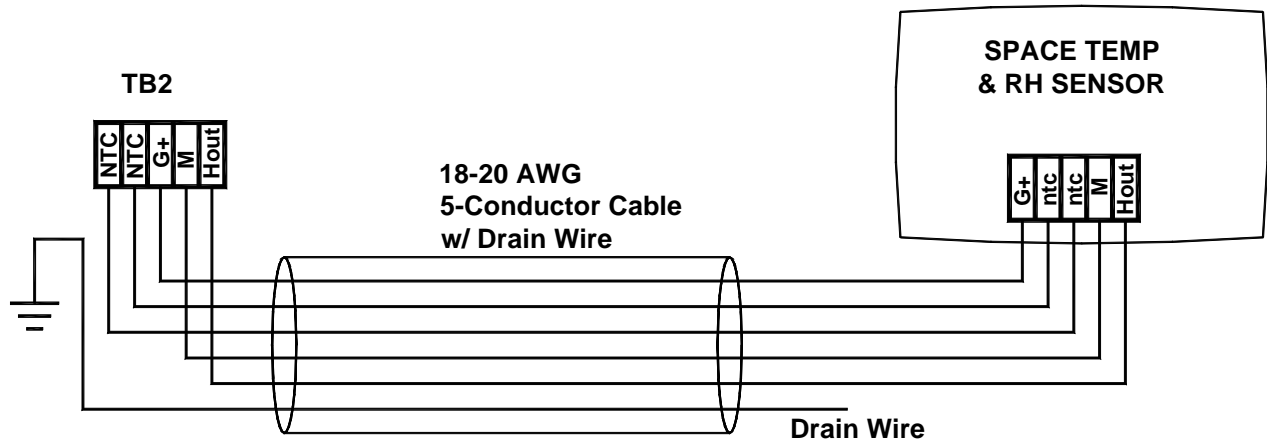
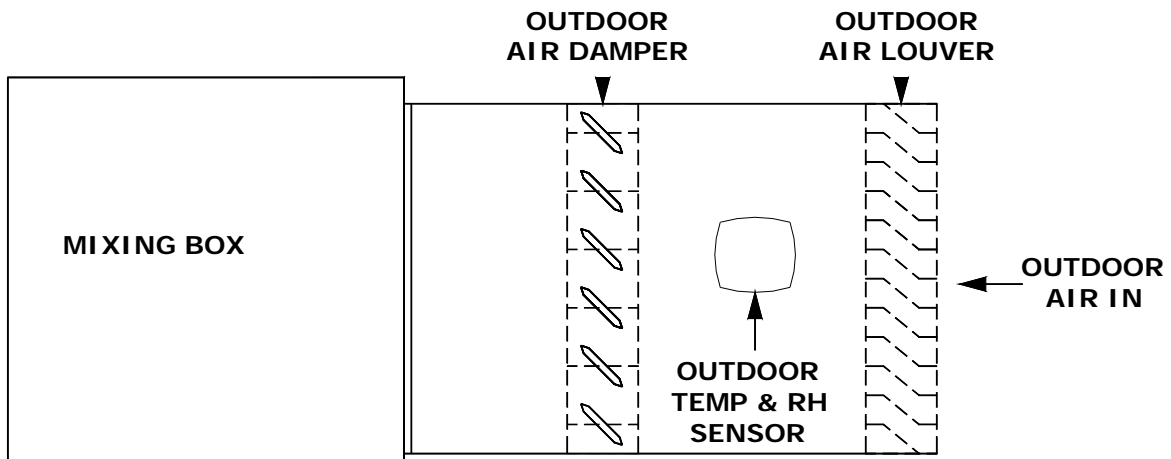

Figure 11 – Space Air Sensor Wiring

**Outdoor Air Sensor Installation**

**Mounting**

Refer to Figure 12 – Outdoor Temp and Humidity Sensor mounting for an illustration of how to install the Duct Mount, Outdoor Air Temperature and Humidity sensor. Install the outdoor air sensor as close to the center of the duct as possible. It may be installed horizontally or vertically. It must be installed between the outdoor air louver and outdoor air damper. A template and mounting hardware are provided with the sensor. Once the position of installation is located, use the template and appropriate size drill bits to locate and drill the holes to install the sensor.



- NOTES:** 1. Outdoor Temp & RH Sensor is Factory Provided & Field Installed.  
 2. Outdoor Air Damper & Louver are Field Provided & Field Installed.

Figure 12 – Outdoor Temp and Humidity Sensor Mounting

## Wiring

Install a minimum 18-20 AWG 5 or 6 conductor shielded cable with drain wire and a minimum 300 volt insulation rating. Refer to Figure 13 – Outdoor Air Sensor Wiring. **Caution: Sensor polarity is important on the humidity side.** Terminate each conductor as follows:

- 1) Terminate TB3-NTC to one of the ntc terminals inside the sensor.
- 2) Terminate TB3-NTC to the other ntc terminal inside the sensor.
- 3) Terminate TB3-G+ to G+ inside the sensor.
- 4) Terminate TB3-M to M inside the sensor.
- 5) Terminate TB3-Hout to H<sub>out</sub> inside the sensor.

**Note: Connect the drain wire to units Ground Lug at the unit's electrical box only.**

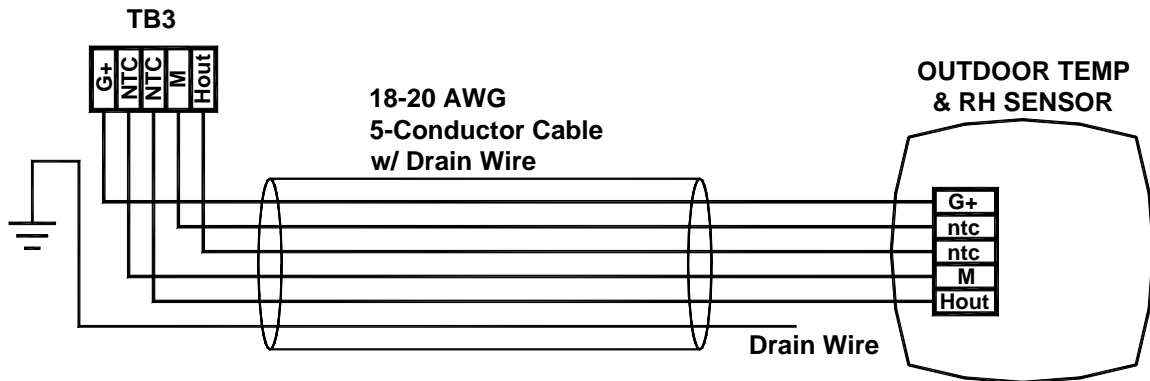

Figure 13 – Outdoor Air Sensor Wiring

## MARVEL CONTROL OPERATION

Upon application of power from the main power supply, control voltage will be applied to the Marvel Controller. The Marvel Control is shipped from the factory in the OFF state.

**CAUTION: If power is disconnected from the unit while the Marvel is in the ON state, the unit will automatically restart when power is reapplied.**

After power is applied, press the ⬅ (enter) button for five seconds and “Off by Keypad” will change to “ON” in the lower line of text. The supply air blower for the evaporator will start after a 30 second default time delay.

## Fan Operation

The supply (evaporator) air blower operates based on the customer configuration (Continuous or On-Demand) which is set under the Factory Setup area. The default setting for the supply air blower from factory is Continuous. Upon initial power up, press the ⬅ (enter) button for five seconds and “Off by Keypad” will change to “ON” in the lower line of text. The supply air blower will energize after a 15 second startup delay. If the On-Demand type of operation is desired, refer to the Factory Setup section under the System Delays screens. When On-Demand type of control is set up, the supply air blower will energize on a call for cooling, heating, humidification, or dehumidification.

## Mechanical Cooling

System compressors are sequenced on in stages based on the demand for cooling. When the air temperature increases above the Room / Return air temperature set point, the cooling demand will start to increase. If the Room / Return air temperature increases above the Room / Return air temperature set point plus  $\frac{1}{2}$  of the band set point, the cooling demand will increase to 100% and Compressor 1 will energize. There is a programmable delay between each stage of compressor set from the factory for 60 seconds. If the cooling demand remains at 100% for more than each stage delay, remaining compressors (if available) are sequenced with a delay between each stage.

As the Room / Return air temperature falls below the Room / Return air temperature set point plus  $\frac{1}{2}$  of the band set point, the cooling demand will start to decrease. If three compressor stages are operating, as soon as the cooling demand becomes less than 75%, Compressor 3 will shut down. As the cooling demand falls below 25%, Compressor 2 will shut down. Finally, as the cooling demand falls below 10%, Compressor 1 will shut down.

**NOTE: When there is a demand for dehumidification, the dehumidification mode will override the cooling mode. This means even though the air temperature might be at or below the Room / Return air temperature set point, the compressors will operate to satisfy the dehumidification requirement. If the air temperature falls below the Room / Return air temperature set point during dehumidification, optional heating will be staged on for the reheat function to temper the air temperature and bring it back up to the Room / Return Air Temperature Set Point. Dehumidification will continue to operate until the requirement is satisfied.**

## Heating

System Heaters are sequenced on/off in stages based on the demand for heating. When the air temperature decreases below the Room / Return Air Temperature Set Point, the heating demand will start to increase. If the Room / Return Air Temperature decreases below the Room / Return Air Temperature Set Point minus  $\frac{1}{2}$  of the band set point, the heating demand will increase to 100% and Heater 1 will energize. There is a slight delay between each stage of heater. If the heating demand remains at 100%, remaining heat stages if available are sequenced on with a slight delay between each stage.

As the Room / Return air temperature increases above the Room / Return air temperature set point, the heating demand will start to decrease. Each stage will be shut down based on the amount of Heat Demand.

## Reheat

If the Room/Return Air Humidity is above the Room/Return Humidity set point plus  $\frac{1}{2}$  the band set point, the dehumidification demand will be 100% and the compressor(s) will energize for dehumidification.

If the Room/Return Air Temperature falls below the Room/Return Air Temperature Set Point minus  $\frac{1}{2}$  the band set point during dehumidification, the heating demand will become 100%. The compressor(s) will continue operating and heating will stage on/off to satisfy the optional reheat function.

## Airside Economizer Option

Airside Economizer is an optional feature that requires a factory provided (field installed) outdoor temperature and humidity sensor. If the Cooling Demand increases and the Outdoor Air Dew Point

Temperature is less than the Room/Return Air Dew Point Temperature Set Point, and the Outdoor Air Temperature is below the Outdoor Air Temperature Set Point minus the Outdoor Air Temperature Band Set Point, the unit will perform Airside Economizer mode of operation. The amount of demand for Airside Economizer can be viewed by looking at the System Demands screen ECON xx%. When operating in airside economizer, the outdoor air dampers are modulated to the position that the ECON demand is calling for.

A minimum damper position setting is available within the advanced factory settings under the **Prg** button in the Factory Settings. Refer to the Economizer screen under the Advanced Factory Settings.

Airside Economizer will shut down when the Cooling Demand becomes 0% or if the Outdoor Air Temperature rises above the Outdoor Air Temperature Set Point plus Outdoor Air Temperature Band Set Point or when the Outdoor Air Enthalpy rises above the Room/Return Air Enthalpy.

The outdoor air enthalpy is calculated by the Outdoor Temperature and Humidity. The Room/Return Air enthalpy is calculated by the Room/Return Air Temperature and Humidity. If the Outdoor Air Enthalpy is lower than the Room/Return Air Enthalpy, then the Outdoor Air is better than the Room/Return Air.

### **Free Cooling Option**

Free Cooling is an option available for a more energy efficient method of cooling when customers have cooling towers available and can provide an entering water temperature to the unit at times of 55°F or less. The Free Cool option requires a factory provided and mounted temperature sensor which is used to monitor the entering water temperature to the unit. If the entering water temperature is below the Free Cool Temperature Set Point minus the Free Cool Temperature Band Set Point, the Marvel Main Board drives a water valve open to use the optional free cool water coil instead of mechanical cooling compressors.

Free Cool Mode will stop when the Cooling Demand is 0% or the entering water temperature increases above the Free Cool Temperature Set Point plus the Free Cool Temperature Band Set Point. If the water temperature increases above the Free Cool Temperature Band Set Point plus Free Cool Temperature Band Set Point and there is still a demand for cooling, the unit will revert back to mechanical cooling with compressors.

### **Modulating Hot Gas Bypass for Low/Partial Load Compressor Management Option**

Modulating Hot Gas Bypass for Low/Light Load Compressor Management is an option used to false load the evaporator coil and compressor system during reduced loading conditions to the evaporator coil. Since the cooling demand has not been completely satisfied the compressor will continue to operate and the evaporator coil may start to freeze. The Marvel Controller regulates the amount of hot gas applied to the evaporator coil to prevent the evaporator coil from freezing based on the cooling demand.

As the Cooling Demand increases, compressors are staged ON/OFF based on the Percentage of Demand for each Compressor and the overall Cooling Demand. As the Cooling Demand decreases to a point where the demand for cooling required is less than 50% demand and less than 100% demand of the first stage compressor, Hot Gas shall be modulated through the modulating Hot Gas Bypass Valve into the Evaporator Coil. If the cooling demand should then start to rise again to a point where the demand is greater than the 100% of cooling demand for the first stage compressor, the Modulating Hot Gas Bypass will modulate closed and if the demand becomes high enough, Compressor(s) 2 and/or 3 will stage on.

## **Room Pressure Control Option**

Typical applications for this type of control are Clean Rooms and Isolation Rooms. Room Pressure Control is an option designed to maintain the air pressure within a room at a room pressure set point. This option requires a factory provided pressure transducer to monitor air pressure within the room being controlled and the adjoining room. The room pressure is then maintained as close to the pressure set point as possible using factory or field provided damper and damper actuators.

When the Room Pressure increases above the Room Pressure Set Point plus Room Pressure Band Set Point, the Marvel control will modulate the damper(s) actuator(s) closed until the Room Pressure Set Point is achieved. If the Room Pressure falls below the Room Pressure Set Point, the Marvel control will modulate the damper(s) actuator(s) open to increase the room pressure until the room pressure set point is achieved.

## **Duct Pressure Control (Adjustable Air Volume) Control Option**

Duct Pressure Control is an option with the Marvel Control System designed to maintain the air pressure within supply air ducting at a duct pressure set point. In a duct pressure control application, the Marvel control can vary the air volume based on a duct pressure sensor reading and a duct pressure set point. The Duct Pressure Control option requires a factory or field provided VFD and a factory provided pressure transducer. This pressure transducer must be 4-20 milliamp type.

The duct pressure is maintained by the VFD ramping the speed (RPM) of the motor up or down to increase or decrease air volume within the supply air ducting. This causes an increase or decrease in static pressure within the ducting. When the Duct Pressure increases above the Duct Pressure Set Point plus Duct Pressure Band Set Point, the Marvel Main Board will decrease the speed of the supply blower motor by modulating the output to the VFD down until the Duct Pressure Set Point is achieved. If the Duct Pressure falls below the Duct Pressure Set Point, the Marvel control will modulate the output to the VFD upward to increase the speed of the supply blower motor to maintain the duct pressure set point.

## **Outdoor Air Damper Control Option**

The Marvel Controller has a digital output to control an outdoor air damper. The damper is controlled based on the operating state (ON/OFF and Occupancy Schedule). The outdoor air damper shall be open as long as the system is in the ON and occupied state. The outdoor air damper shall close whenever the unit is OFF or in the UnOccupied state.

The outdoor air damper will also close whenever the Room Humidity is greater than the Room Humidity High Alarm Set Point basically overriding the Cooling Demand closing the damper to prevent extremely humid conditions in the space being controlled. If the Room Humidity rises above the Room Humidity High Alarm Set Point, an alarm is also annunciated on the Marvel Wall Controller and the Outdoor Air Damper is closed.

## MARVEL TERMINAL KEYPAD AND DISPLAY OPERATION

This section is provided as a guide to explain the functions of each of the menus and their associated screens. By pressing the **Prg** button, each of the submenus listed previously on page 9 will appear. Listed below is a description of each of the submenus and the screens for readings and settings under those specific submenus. To navigate through the functions listed under a particular submenu, press the **↑** or **↓** buttons while the specific submenu appears in the display.

If there is a changeable parameter/setting under a particular screen, press the **←** button to navigate the cursor to the parameter where the change is desired then use the **↑** or **↓** buttons to change to the newly desired parameter/setting and press **←**.

Each screen shown in the following pages is defined to explain the operation for readings, parameters, and settings within the system.

### ENTER BUTTON **←**





Upon application of power to the system, the main identifier screen appears. Press the **Esc** button to clear the main identifier screen and the unit's main status Esc will appear. To turn the system on, press the **←** button and hold for five (5) seconds. Likewise, to turn the system off, press the **←** button and hold for an additional (5) seconds.



The CoolAir Corporation screen identifies the manufacturer of the equipment provided, software version, and date the software was last modified.

After a start-up delay of approximately 15 seconds, the evaporator blower will start. Another delay of 60 seconds (default but adjustable) occurs before any modes of operation (cooling, heating, humidification, or dehumidification) are performed.

### **ALARM BUTTON** (Alarms and Resetting)

When an Alarm occurs, an audible alarm buzzer will sound off to alert the customer of the alarm condition. The LED indicator inside the  button will illuminate Red. Present Alarms are displayed in English text in order of occurrence. Press the  button one time to display the present and most recent alarm condition. Press the **↓** button to display all remaining alarms that may be present. When the  button is pressed one time, the audible alarm will silence. In an alarm condition, the appropriate system's stage or mode of operation is shut down preventing the particular stage or mode from operation to protect it. Once repairs are made to the particular mode or stage, pressing the  button and holding it for a few seconds will clear the Red LED indicator.

For example, if the low pressure switch for Compressor 1 opens due to a low refrigerant pressure condition, Compressor 1 Low Pressure will be displayed when the  button is pressed. Compressor 1 will be shut down and locked out from operation until repairs are made to Compressor 1's refrigerant system.





**DANGER:** BEFORE ATTEMPTING TO TROUBLESHOOT A SYSTEM ALARM, BE AWARE THAT REFRIGERANT CONTAINED IN EACH COMPRESSOR SYSTEM AND HOT WATER OR STEAM FROM HEATING COILS CAN CAUSE SEVERE BURNS. HIGH VOLTAGE AND OPERATING FAN DRIVES ALSO PRESENT HAZARDOUS CONDITIONS. BE AWARE OF THE DANGERS AND CONTACT APPROPRIATE PERSONNEL OR CERTIFIED TECHNICIANS TO SERVICE THE EQUIPMENT.

The following is a general description of the alarms and how they react within the system. To reset the alarm, follow the reset instructions listed in each specific alarm type.

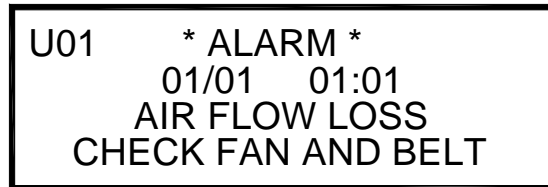
### Air Flow Loss

When there is a loss of air flow condition, the air switch will open to digital input 1 (ID1) of the Marvel Main Board creating a loss of airflow alarm condition. The screen below will be displayed when the  button is pressed on the wall mount Terminal unit. All modes of operation (heating, cooling, humidification, and dehumidification) and the supply air blower shut down to protect the system. All modes are locked out from operation until the problem is located and corrected. Check for broken or slipping v-belts as the root cause as well as a possible defective supply air motor.



To reset the alarm, press the *Prg* button multiple times until the SYSTEM ENABLES menu appears. Next, press the  button until System Enables **System** screen appears. Press  one time to drop the blinking cursor underneath System OFF. Press  or  one time until ON appears then press  again.

### Heater High Limit

When an extreme high temperature condition occurs in the surrounding area of the electric heater elements due to conditions such as low air flow, etc., the heater high limit switch will open to digital input 2 (ID2) of the Marvel Main Board creating a heater high limit alarm condition. At that point, the electric heaters are shut down by the Main Board and the screen below will be displayed on the wall mount Terminal unit when the  button is pressed. When the temperature falls below the heater high limit switch's cut-out point, the heat will automatically cycle on again. The alarm will continue as long as there is a heater high limit condition.





To reset the alarm determine the cause for high limit failure and correct it. The reason for failure may be lack of air flow, a shorted heater or other condition. Once corrected, press and hold the  button until the Red LED indicator turns off. Heaters remain enabled as a default and automatically restart when the Heater High Limit Switch resets.

## Dirty Filter Switch

When the evaporator unit(s) air filter becomes excessively dirty, the dirty filter switch will open to the Marvel Main Board digital input 3 (ID3). An audible alarm is generated on the wall control Terminal unit and the screen below appears when the  button is pressed. This alerts the operator that the air filter is dirty and should be changed. The system continues to operate in all modes even with this alarm.

If the unit is equipped with a condenser filter, verify this filter is not dirty.







U01	* ALARM *
01/01	01:01
FILTER DIRTY	
CHECK FILTER	

To reset the alarm after the filter is changed, press and hold the  button until the Red LED turns off. The audible alarm is turned off by pressing the  button one time.

## Drain Pan Alarm

When the water level in the condensate drain pan rises above the trip point of the drain pan overflow switch because there is a blockage in the condensate drain piping, the condensate drain pan switch will open to the Marvel Main Board at digital input 4 (ID4) creating a drain pan overflow alarm. At that point, all modes of operation are shut down and locked out from operation until the reason for condensate overflow is located and corrected. The following screen will be displayed.







U01	* ALARM *
01/01	01:01
DRAIN PAN ALARM	

Locate the reason for the failure such as a blockage in the condensate drain or drain piping and correct the situation. Press and hold the  button down until the Red LED indicator in the  button turns off. To reset the alarm, press the *Prg* button multiple times until the SYSTEM ENABLES menu appears. Next, press the  button until System Enables **System** appears. Press the  button one time to drop the blinking cursor under the OFF. Press the  or  button one time until ON appears then press  again.

## Freeze Stat Alarm Option

If the surface of the evaporator coil starts to fall below the temperature setting of the optional freeze stat, the freeze stat thermostat will open to the Marvel Main Board at digital input 4 (ID4) creating a freeze stat alarm condition. At that point, all modes of operation are shut down and locked out from operation until the reason for coil freeze up condition is located and corrected. The following screen will be displayed.







```
U01      * ALARM *
          01/01  01:01
          FREEZE STAT ALARM
```

To reset the alarm, press and hold the  button down until the Red LED indicator in the  button turns off. Press the *Prg* button multiple times until the SYSTEM ENABLES menu appears. Next, press the  button until System Enables **System** appears. Press the  button one time to drop the blinking cursor under the OFF. Press the  or  button one time until ON appears then press  again.

### Compressor 1 Low Pressure

If Compressor 1 is operating with low refrigerant charge due to a leak in the piping, a defective valve, dirty filter drier, etc., then the Compressor 1 low pressure switch will open to the Marvel Main Board digital input 5 (ID5) and create a low pressure alarm. The Main Board will lock out Compressor 1 from operation. The following screen will be displayed when the  button is pressed. If this screen appears, it is recommended to have a technician troubleshoot the system.





```
U01      * ALARM *
          01/01  01:01
          COMPRESSOR 1
          LOW PRESSURE
```

To reset the alarm, press and hold the  button down until the Red LED indicator in the  button turns off. Press the *Prg* button multiple times until the SYSTEM ENABLES menu appears. Next, press the  button until System Enables **Compressors** screen appears. Press  one time to drop the blinking cursor under the OFF. Press  or  one time until ON appears then press  again. This compressor circuit will now re-energize if there is a requirement for it to operate.

### Compressor 1 High Pressure

If Compressor 1 is operating in a high pressure state due to a dirty condenser coil lack of air flow, etc., and the Compressor 1 high pressure switch opens to the Marvel Main Board digital input 6 (ID6) creating a high pressure alarm. The Main Board will lock out Compressor 1 from operation. The following screen will be displayed when the  button is pressed. If this screen appears, it is recommended to have a technician troubleshoot the system.

```
U01      * ALARM *
          01/01  01:01
          COMPRESSOR 1
          HIGH PRESSURE
```







Press the *Prg* button multiple times until the SYSTEM ENABLES menu appears. Next, press the  button until System Enables **Compressors** screen appears. Press  one time to drop the blinking cursor under the OFF. Press  or  one time until ON appears then press  again. This compressor circuit will now re-energize if there is a requirement for it to operate.

**NOTE: On systems with R410A Refrigerant, a manual reset of the high pressure switch is also required.**

### Compressor 2 Low Pressure

If Compressor 2 is operating with low refrigerant charge due to a leak in the piping, a defective valve, dirty filter drier, etc., then the Compressor 2 low pressure switch will open to the Marvel Main Board digital input 7 (ID7) and create a low pressure alarm. The Main Board will lock out Compressor 2 from operation. The following screen will be displayed when the  button is pressed. If this screen appears, it is recommended to have a technician troubleshoot the system.





```
U01      * ALARM *
          01/01  01:01
          COMPRESSOR 2
          LOW PRESSURE
```

To reset the alarm, press and hold the  button down until the Red LED indicator in the  button turns off. Press the **Prg** button multiple times until the SYSTEM ENABLES menu appears. Next, press the  button until System Enables **Compressors** screen appears. Press  one time to drop the blinking cursor under the OFF. Press  or  two times until ON appears then press  again. This compressor circuit will now re-energize if there is a requirement for it to operate.

### Compressor 2 High Pressure

If Compressor 2 is operating in a high pressure state due to a dirty condenser coil, lack of air flow, etc., and the Compressor 1 high pressure switch opens to the Marvel Main Board digital input 8 (ID8) creating a high pressure alarm. The Main Board will lock out Compressor 2 from operation. The following screen will be displayed when the  button is pressed. If this screen appears, it is recommended to have a technician troubleshoot the system.

```
U01      * ALARM *
          01/01  01:01
          COMPRESSOR 2
          HIGH PRESSURE
```







Press the **Prg** button multiple times until the SYSTEM ENABLES menu appears. Next, press the  button until System Enables **Compressors** screen appears. Press  one time to drop the blinking cursor under the OFF. Press  or  two times until ON appears then press  again. This compressor circuit will now re-energize if there is a requirement for it to operate.

**NOTE: On systems with R410A Refrigerant, a manual reset of the high pressure switch is also required.**

### Compressor 3 Low Pressure

If Compressor 3 is operating with low refrigerant charge due to a leak in the piping, a defective valve, dirty filter drier, etc., then the Compressor 3 low pressure switch will open to the Marvel Main Board digital input 11 (ID11) and create a low pressure alarm. The Main Board will lock out Compressor 3 from operation. The following screen will be displayed when the  button is pressed. If this screen appears, it is recommended to have a technician troubleshoot the system.





```
U01      * ALARM *
          01/01  01:01
          COMPRESSOR 3
          LOW PRESSURE
```

To reset the alarm, press and hold the  button down until the Red LED indicator in the  button turns off. Press the *Prg* button multiple times until the SYSTEM ENABLES menu appears. Next, press the  button until System Enables **Compressors** screen appears. Press  three times to drop the blinking cursor under the OFF. Press  or  one time until ON appears then press  again. This compressor circuit will now re-energize if there is a requirement for it to operate.

**Compressor 3 High Pressure**

If Compressor 3 is operating in a high pressure state due to a dirty condenser coil, lack of air flow, etc., and the Compressor 3 high pressure switch opens to the Marvel Main Board digital input 12 (ID12) creating a high pressure alarm. The Main Board will lock out Compressor 3 from operation. The following screen will be displayed when the  button is pressed. If this screen appears, it is recommended to have a technician troubleshoot the system.





```
U01      * ALARM *
          01/01  01:01
          COMPRESSOR 3
          HIGH PRESSURE
```

To reset the alarm, press the *Prg* button multiple times until the SYSTEM ENABLES menu appears. Next, press the  button until System Enables **Compressors** screen appears. Press  one time to drop the blinking cursor under the OFF. Press  or  three times until ON appears then press  again. This compressor circuit will now re-energize if there is a requirement for it to operate.

**NOTE: On systems with R410A Refrigerant, a manual reset of the high pressure switch is also required.**  
**Smoke Detector**

When an optional smoke detector is attached to the Marvel Main Board, and the smoke detector contacts open due to a smoke/fire condition, the unit will shut down all modes of operation even the supply air blower and lock them out from operation to prevent adding air into the rooms being conditioned. The following screen will be displayed.

```
U01      * ALARM *
          01/01  01:01
          SMOKE DETECTION
          SYSTEM OFF
```

To reset the alarm, press and hold the  button down until the Red LED indicator in the  button turns off. Press the *Prg* button multiple times until the SYSTEM ENABLES menu appears. Next, press the  button until System Enables **System** appears. Press the  button one time to drop

the blinking cursor under the OFF. Press the **↑** or **↓** button one time until ON appears then press **←** again. The system will now turn on.

## **MAIN STATUS SCREENS**

In this section all main control readings will be displayed. To enter this section, press the **Esc** button several times until the Room/Return screen listed below appears, then use the **↑** or **↓** buttons to toggle through the screens to locate the desired readout. The following is a list of the screens with a description of their function:

```
U01 RETURN/ROOM
TEMPERATURE :072.4 F
HUMIDITY      :053.9%RH
ON              DEH
```

This Return/Room screen displays the Temperature and Humidity of the Return or Room Air based on the type of sensor is being used Return Air (Duct Mount) or Room Air (Wall Mount). It also displays the status of the unit operation if the word ON appears, the unit is operating. If nothing appears in the bottom line, the unit is off. When the unit is calling for humidification or dehumidification, HUM or DEH will appear in the bottom line.

```
U01 OUTPUT STATUS
COOLING STAGES: C12
HEATING STAGES: OFF
CONDENSER FAN: ON
```

The output status screen displays how many stages of Cooling or Heating are operating. The output status tracks the system demands. As the system demands increase for a desired mode of operation (cooling / heating) the number of stages for that particular mode increases. If the system is calling for cooling, the Condenser Fan should read on. If the system is a heat pump system, the condenser should read on.

**NOTE: If the system has modulating heat, the amount of heat operating, will not show up under the heating stages, likewise if the system has a modulating valve for a chilled water, the amount of cooling will not show up under the cooling stages. These are best tracked by the System Demand. As the demand increases for a particular component, the analog output voltage will increase based on the percentage of demand being called for.**

### **Optional Sensors**

The following “OPTIONAL SENSORS screens show the sensors that are required to perform these optional functions: Airside Economizer, Free Cooling, Modulating Hot Gas Bypass, Discharge Air Temperature Control, and Room Pressure Control. If the system does not have any of those particular sensors installed, then the sensor will not show up. Likewise if none of the sensors are installed, the screens do not show up.

```
U01 OPTIONAL SENSORS
OA TEMP      : 054.0 F
FREE COOL T : 064.0 F
DISCH TEMP  : 082.0 F
```

```
U01 OPTIONAL SENSORS
DUCT PRESSURE: 0.92 I
OUTSIDE HUM   048.3%
VFD Feedback: 56.4Hz
```

```
U01 SYSTEM DEMANDS
COOL  : 100%
HEAT  : 000%
HUMIDIFY : 000%
```

The "SYSTEM DEMANDS" screen listed above displays system demands for cooling, heating, and humidification. To satisfy the setting for temperature and humidity, these demands display how much of each mode is required for the system to reach the temperature and humidity set points.

```
U01 SYSTEM DEMANDS
ECON  : 100%
DEHUM : 000%
```

The screen above displays "SYSTEM DEMANDS" for economizer and dehumidification functions. To satisfy the setting for temperature and humidity, these demands display how much of each mode is required for the system to reach the temperature and humidity set points.

```
U01
      Tuesday
      November 09, 2010
      10:07
```

The screen above appears only if the following two conditions are met:

- A) A Time Clock Card is installed
- B) The Night Set Back mode is set to OFF.

```
U01 06/14/05 11:17
MODE: TUE OCC
OVERRIDE MODE> OFF
OVERRIDE TIME>060min
```

The screen above is used to over ride the unoccupied period of operation. This screen only appears if the Night Set Back mode under the Time Clock Settings submenu is enabled ON.

To over ride an unoccupied time from this screen, the unit MODE must first be unoccupied "UNOCC". Press the ← button and the cursor will drop below the OFF next to Override Mode. The flashing cursor repositions under the OFF of the Override Mode setting. Press ↑ or ↓ one time to set Override Mode OFF to ON and then press the ← button again. Using the ↑ or ↓ buttons, select the desired length of time for Override Mode then press ← one last time.

**SET POINTS**

Press the *Prg* button one time to access the screens for changing the temperature, humidity, or optional pressure settings. Once the Set Points screen appears, use the ↑ or ↓ buttons to move to the screen of the desired setting to change (see the screens listed below). The only screens available to the customer are the ones that appear. If one of the screens listed below does not appear, the system may not have that particular function as the option was not ordered.

To change a specific setting, scroll to the screen where that particular setting is located then press the ← button to move the blinking cursor under the setting. Next, press the ↑ or ↓ buttons to change the setting and press ← again.



The Set Points screen allows the operator to know they have entered the Set Point adjustment section of the program.

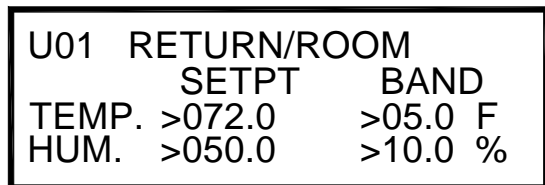

Temperature and Humidity settings are changed from the Return/Room screen. The band is used to set the activation point for heating or cooling. If the temperature rises above the temperature setting plus one half the band setting, the Cooling Demand will increase. If the temperature falls below the tempature setting minus one half the band setting, the heating demand will increase.

Likewise with humidity, if the humdity rises above the humidity setting plus one half the band setting, the Dehumidification Demand will increase. If the humidity falls below the humidity setting minus one half the band setting, the Humidification Demand will increase.

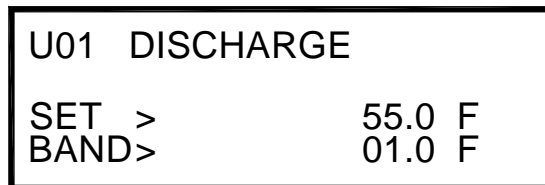

The Discharge set points screen is used to control the staging of the compressors based on discharge air temperature set point.

U01 FREECOOL SET  
WATER TEMPERATURE  
SETPOINT >055.0 F  
BAND >005.0 F

The Freecool Set screen is used to set the temperature setting for the activation point of free cool mode. If the entering water temperature is below the free cool temperature setting minus the band setting, the water valve will drive full open to enable free cooling mode and disable mechanical cooling. Free cooling will shut down when the Return/Room set point is met, or when the entering water temperature rises above the free cool set point plus band set point.

U01 OA SETPOINTS  
ECONOMIZER SET POINT  
SETPOINT >055.0 F  
BAND >005.0 F

The OA Setpoints screen is used to set the Outdoor Air Temperature Set Points for activation of the Airside Economizer option. It allows the customer to change the activation temperature for outdoor air economizer. When there is a cooling demand, the unit will operate in the Airside Economizer mode when the Outdoor Air Temperature falls below the Outdoor Air Temperature Set Point minus the Outdoor Air Temperature Band Set Point, and the Outdoor Air Enthalpy is lower than the Room/Return Air Enthalpy, the Marvel Main Board will activate Airside Economizer. The unit will operate in Airside Economizer mode until the room/return air temperature reaches set point or the outdoor air enthalpy rises above the room/return air enthalpy or the outdoor air temperature increases above the outdoor air temperature set point plus outdoor air temperature band set point.

U01 RETURN/ROOM  
TEMPERATURE ALARMS  
HIGH > 090.0 F  
LOW > 055.0 F

The Return/Room Temperature Alarms screen is used to set the Return/Room Air Temperature High and Low Temperature Alarm Set Points. If the air temperature rises above or falls below the temperature alarm set points for more than five minutes, the unit will sound an audible alarm to alert the operator of the alarm condition.

U01 RETURN/ROOM  
HUMIDITY ALARMS  
HIGH > 065.0%RH  
LOW > 035.0%RH

The Return/Room Humidity Alarms screen is used to set the Return/Room Air Humidity High and Low Humidity Alarm Set Points. If the air humidity rises above or falls below the humidity alarm set points for more than five minutes, the unit will sound an audible alarm to alert the operator of the alarm condition.

U01 VFD LOW CUTOUT  
HEAT > 20.0Hz  
COOL> 20.0Hz

The VFD Low Cutout screen is used to set the shut down points for heating and cooling if the VFD Feed Back position signal alerts the Marvel Control the motor speed is less than the setting heating or cooling shut down frequency.

U01 WATER PURGE  
PURGE TIME  
HH:00 MM:00  
Length:00Min

On units with Free Cool, Chilled Water, or Water Cooled Condensers, a digital output can be configured and used to start the auxiliary water pump when the cooling demand increases to provide the water flow required for cooling mode. The Water Purge screen is used to set a time schedule and length of time to flush water that has been free standing in the water piping for a long period of time when there is no cooling demand. To set the Time and Length, press the ← button to move the cursor under the HH (Hour), MM (Minute), and Length then use the ↑ or ↓ button to change the set points. Press the ← button to accept the change in set point.

**TIME CLOCK SETTINGS**

The clock button allows access to the optional Real Time Clock setup as well as Night Set Back operation and setup. To access this section, press the **Prg** button two times then use the ↑ or ↓ button to scroll to the screen of the desired change. Press the ← button to move the cursor to the desired change on the particular page and use the ↑ or ↓ buttons to change the setting. Press the ← button again to accept the change then press **Esc** to exit the clock settings area.

U01  
Time Clock  
Settings

The Real Time Clock Set Points screen is used as an identifier to let the customer know they are under the Real Time Clock Set Points section.

U01 Daylight  
Savings Time  
> ON

The Daylight Savings Time screen is used to enable daylight savings time if the location of operation observes daylight savings time. By enabling the daylight savings time to ON. The

System will automatically switch to and out of daylight savings time based on the date that savings time occurs.

```
U01
    Night Set Back
    > ON
    NSB Min ON >300s
```

The Enable Night Setback screen is used to turn Night Set Back (NSB) ON or OFF. Once night setback is ON, the timer will appear below the setback. The NSB Min ON setting is used to allow the system a minimum time to operate in night set back mode before an Unoccupied Override of the system can be enabled.

```
U01 REAL TIME CLOCK
DAY > TUE
TIME > 15:43
DATE > 06/14/05
```

The Real Time Clock Day, Time, and Date screen is used to adjust the Day of the week, Time, and Date.

```
U01 NIGHT SETBACK
TEMP CONTROL >OFF
HIGH TEMP >090.0 F
LOW TEMP >055.0F
```

The Night Set Back Temp Control screen is used to set the highest and lowest temperatures before cooling or heating will be activated to satisfy the set point. From the screen above, the air temperature must rise above 90°F before cooling will activate, and the air temperature must fall below 55°F before heating will activate. If Temp Control is set to off, the unit will follow normal heating and cooling demands.

```
U01 NIGHT SETBACK
HUM CONTROL >OFF
HIGH HUM >065.0%
LOW HUM >035.0%
```

The Night Set Back Hum Control screen is used to set the highest and lowest humidity settings before humidification or dehumidification will be activated to satisfy the set point. From the screen above, the air humidity must rise above 65% before dehumidification will activate, and the air humidity must fall below 35% before the humidifier will activate. If Hum Control is set to off, the unit will follow normal humidification and dehumidification demands.

```
U01    NITE SUN> YES
MON > YES  TUE > YES
WED > YES  THU > YES
FRI  > YES  SAT > YES
```

The screen above lists each night of the week for the night set back to operate. Only the days of the week set to yes will follow a night set back schedule.

```
U01    OCC  SUN>06:00
MON >06:00 TUE >06:00
WED >06:00 THU >06:00
FRI  >06:00 SAT >06:00
```

The screen above is used to switch each day of the week to occupied at the select time set into the occupied time for each day.

```
U01  UNOCC  SUN>18:00
MON >18:00  TUE >18:00
WED >18:00  THU >18:00
FRI  >18:00  SAT >18:00
```

The screen above is used to switch each day of the week to unoccupied at the select time set into the unoccupied time for each day.

### **SYSTEM ENABLES MENU**

The SYSTEM ENABLES menu is the system enables sections, which is used to toggle the mode of operation stages on or off. Some of the modes are automatically toggled off to lock out a particular mode or stage of operation based on the type of alarm failure that occurs. To toggle any one of the components ON or OFF to reset it (enable or disable) from its displayed screen, press the ← button while on the selected screen to move the cursor down to the desired component to reset then press the ↑ or ↓ and press ← again. Once reset, press the **Esc** button to exit this section.

```
U01
  SYSTEM ENABLES
```

The System Enables screen allows the operator to know they are in the System Enables section of the program. When an alarm occurs, the component affected by the alarm must be re-enabled within this section.

U01    SYSTEM ENABLES SYSTEM        >ON HUMIDIFIER >ON DEHUMIDIFY >ON
--

The System Enables screen for System, Humidifier, and Dehumidify allows the operator to enable or disable these particular modes of the system. Switching the System to OFF will shut down the entire system.

**CAUTION: Power is still applied to the unit when switching the enable for System to OFF.**

U01    SYSTEM ENABLES COMPRESSORS 1>ON            3>ON 2>ON
--

The system enables screen for Compressors allows each compressor in the system to be toggled on or off. Any compressor circuit that is off under this enable screen will not turn on when there is a cooling demand.

**NOTE: IF THE COMPRESSORS ARE NOT OPERATING AND THE TEMPERATURE AND/OR HUMIDITY ARE ABOVE THE SET POINTS,** it does not indicate the unit has a defective control board or compressor. It may be an indication the System Enables Compressors is set to OFF. Checking this is an important requirement before stating the board is defective.

U01    SYSTEM ENABLES HEATERS 1>ON            3>ON 2>ON            4>ON
--

The system enables screen for Heaters allows each heater stage in the system to be toggled on or off. Any heater circuit that is off under this enable screen will not turn on when there is a heating demand.

U01    REHEAT LOCK OUT 1>NO            3>YES 2>YES           4>YES
--

The Reheat Lock Out screen is used to select which ON/OFF type heating stage(s) will be used as reheat and which stage may be used a both heat and reheat.

U01 MODULATING  
REHEAT LOCK OUT > YES

The Modulating Reheat Lock Out screen is used to select if the Modulating Heater is used for heating only or modulating reheat. Set to Yes if the Modulating Heating is locked out from Reheat. Set to No if the Modulating Heat is used for Reheat.

### EQUIPMENT RUN HOURS

The wrench button allows the service equipment run hours to be viewed for heating, cooling, fan, humidification, and dehumidification. It also displays the 24 hour high and low temperature and humidity of the system.

U01  
EQUIPMENT RUN  
HOURS

The Equipment Run Hours screen is used as an identifier to let the customer know they are under the Equipment Run Hours section. This section allows the customer to know how long each component has been operating since the system was put into service.

U01 RUN HOURS  
ACTUAL  
FAN > 00020  
HUMIDIFY > 00005

The Run Hours for Fan and Humidify identifies the length of time the supply air blower and humidifier have been in operation since the system was put into service.

U01 RUN HOURS  
ACTUAL  
COMP 1 > 00014  
COMP 2 > 00012

The Run Hours screen for Compressors identifies the length of time each compressor has been in operation since the system was put into service.

U01 RUN HOURS  
ACTUAL  
COMP 3 > 00004

```

U01  RUN HOURS
      ACTUAL
HEAT 1  >  00004
HEAT 2  >  00003

```

The Run Hours screens for Heat Stages identifies the length of time that each stage of heat has been in operation since the system was put into service.

```

U01  RUN HOURS
      ACTUAL
HEAT 3  >  00002
HEAT 4  >  00002

```

```

U01  24 HOUR HIGH/LOW
      LOW      HIGH
TEMP: 071.2 F  075.8 F
HUM  : 047.3% 058.2%

```

The 24 Hour High/Low Temperature and Humidity screen above tracks the highest and lowest Room/Return Temperature and Humidity over a 24 Hour time span.

**ANALOG/DIGITAL INPUT SETUP MENU**

The information screens are used for adjusting alarm switching devices (digital inputs) and calibrating sensors (analog inputs). To adjust sensor calibration or alarm switching devices as appears in the following screens, press the **info** button and then use **↑** or **↓** buttons to navigate to that particular screen for the desired change. While on that screen, press the **←** button to navigate the cursor to the desired item to change and then use the **↑** or **↓** to change the desired setting. When finished, press the **←** button again to navigate the cursor back up to the unit identification number Uxx. If any of the screens do not appear as shown below, the unit has not been supplied with that optional alarm feature or sensor.

**Sensors**

```

U01
  ANALOG/DIGITAL
  INPUT SETUP

```

The Analog (Sensor) and Digital (Alarm) Input Setup screen allows the operator to know they have entered the calibration section of the program. Press the arrow down button one time to get to the first calibration screen.

```
U01      SENSOR SETUP
RETURN/ROOM
CAL OFFSET > 000.0 F
ACTUAL IN : 072.5 F
```

The sensor setup screen for Return/Room Temperature allows the operator to calibrate the Return/Room Temperature to a calibrated temperature sensor. If a sensor is out of calibration by more than 10°F, it is highly recommended to replace the sensor. To adjust the calibration, press the ← button to move the cursor under the Cal Offset setting then use the ↑ or ↓ buttons to change the offset. Press ← on confirm the change in calibration and it will appear under the actual in.

```
U01      SENSOR SETUP
RETURN/ROOM
CAL OFFSET > 000.0 %RH
ACTUAL IN : 053.2 %RH
```

The sensor setup screen for Return/Room Humidity allows the operator to calibrate the Return/Room Humidity to a calibrated humidity sensor. If a sensor is out of calibration by more than 10%, it is highly recommended to replace the sensor. To adjust the calibration, press the ← button to move the cursor under the Cal Offset setting then use the ↑ or ↓ buttons to change the offset. Press ← to confirm the change in calibration and it will appear under the actual in.

```
U01      SENSOR SETUP
DISCH TEMPERATURE
CAL OFFSET > 000.0 F
ACTUAL IN : 061.5 F
```

The sensor setup screen for Discharge Temperature allows the operator to calibrate the Discharge Temperature to a calibrated temperature sensor. If a sensor is out of calibration by more than 10°F, it is highly recommended to replace the sensor. To adjust the calibration, press the ← button to move the cursor under the Cal Offset setting then use the ↑ or ↓ buttons to change the offset. Press ← to confirm the change in calibration and it will appear under the actual in.

```
U01      SENSOR SETUP
OUT AIR TEMPERATURE
CAL OFFSET > 000.0 F
ACTUAL IN : 088.5 F
```

The sensor setup screen for the Outdoor Air Temperature sensor allows the operator to adjust the calibration of the outdoor air sensor for the Airside Economizer option. If a sensor is out of calibration by more than 10°F, it is highly recommended to replace the sensor. To adjust the calibration, press the ← button to move the cursor under the Cal Offset setting then use the ↑ or ↓ buttons to change the offset. Press ← on confirm the change in calibration and it will appear under the actual in.

```
U01      SENSOR SETUP
OUT AIR HUMIDITY
CAL OFFSET > 000.0%RH
ACTUAL IN : 048.0%RH
```

The sensor setup screen for Outdoor Air Humidity allows the operator to calibrate the Outdoor Air Humidity to a calibrated humidity sensor. If a sensor is out of calibration by more than 10%, it is highly recommended to replace the sensor. To adjust the calibration, press the ← button to move the cursor under the Cal Offset setting then use the ↑ or ↓ buttons to change the offset. Press ← to confirm the change in calibration and it will appear under the actual in.

```
U01      SENSOR SETUP
WATER TEMPERATURE
CAL OFFSET > 000.0 F
ACTUAL IN : 053.0 F
```

The sensor setup screen for Water Temperature allows the operator to calibrate the Water Temperature sensor to a calibrated temperature sensor. If a sensor is off by more than 10°F, it is highly recommended to replace the sensor. To adjust the calibration, press the ← button to move the cursor under the Cal Offset setting then use the ↑ or ↓ buttons to change the offset. Press ← to confirm the change in calibration and it will appear under the actual in.

```
U01      SENSOR SETUP
DUCT PRESSURE
CAL OFFSET > 0.0IWG
ACTUAL IN : 0009
```

The sensor setup screen for Duct Pressure allows the operator to calibrate the Duct Pressure Transducer to a calibrated pressure transducer. If a sensor is off by more than 0.5" W.C., it is highly recommended to replace the sensor. To adjust the calibration, press the ← button to move the cursor under the Cal Offset setting then use the ↑ or ↓ buttons to change the offset. Press ← to confirm the change in calibration and it will appear under the actual in.

```
U01      DUCT PRESSURE
4mA=      0.0
20mA=     5.0
```

The sensor setup screen for Duct Pressure allows the operator to adjust start and stop points based on the sensor provided for improved accuracy. For instance, the sensor could be a 0-5.0" W.C. Pressure Transducer over a 4-20mA range. The control set point might be 1.0 " W.C. For better accuracy, this range of 0-5" W.C. could be tightened up so there is less swing in the range. Setting would be to adjust the 20 mA setting from 5.0" W.C. to 2.0" W.C.

the Duct Pressure Transducer to a calibrated pressure transducer. If a sensor is off by more than 0.5" W.C., it is highly recommended to replace the sensor. To adjust the calibration, press the ←

button to move the cursor under the Cal Offset setting then use the  $\uparrow$  or  $\downarrow$  buttons to change the offset. Press  $\leftarrow$  to confirm the change in calibration and it will appear under the actual in.

```
U01    SENSOR SETUP
VFD FEEDBACK
CAL OFFSET > 0.0Hz
ACTUAL IN  : 0570
```

This screen allows the operator to adjust calibration of the Feedback for the VFD. This Feedback designates the operational position of the VFD to the Marvel Main Board.

```
U01    SENSOR SETUP
VFD Feedback
4mA=    00.0Hz
20mA=   60.0Hz
```

This screen allows the operator to adjust the Frequency Range so that the minimum Frequency position will always start at 4 mA equals 0 Hz and the maximum frequency will always be 60 Hz.

### Alarm Contacts

The default setting for all screens listed below is alarms on open with the only exception being the Remote ON contact which alarms on close. Remote On was set up to alarms on close which is similar to turning a light on using a light switch. The switch gives the contact closure to the light which causes it to turn on. The contact closure to the Remote ON digital input on the Marvel Main Board will activate the unit's control circuit which starts the unit. Listed next to the Alarms On is the Active state of each switch for their corresponding digital input. The Active state is the present position of the switch. When the Alarms ON and Active state read the same, the alarm sequence becomes active and the corresponding alarms must be corrected following the instructions for the corresponding alarm under the Alarm Button section.

```
U01    DIGITAL INPUTS
ALARMS ON:      ACT
AIRFLOW >OPEN  CLOSE
HI-HEAT >OPEN  CLOSE
```

```
U01    DIGITAL INPUTS
ALARMS ON:      ACT
FILTER >OPEN    CLOSE
DRAIN >OPEN    CLOSE
```

```
U01    DIGITAL INPUTS
ALARMS ON:      ACT
C1 LP >OPEN     CLOSE
C1 HP >OPEN     CLOSE
```

```
U01    DIGITAL INPUTS
ALARMS ON:      ACT
C2 LP    >OPEN  CLOSE
C2 HP    >OPEN  CLOSE
```

```
U01    DIGITAL INPUTS
ALARMS ON:      ACT
C3 LP    >OPEN  CLOSE
C3 HP    >OPEN  CLOSE
```

```
U01    DIGITAL INPUTS
ALARMS ON:      ACT
REMOTE > CLOSE  CLOSE
SMOKE > OPEN   CLOSE
```

**PRG & Esc - (FACTORY SETUP MENU)**

The following screens under the combination **Prg** (program) and **Esc** (escape) buttons are the Factory Settings. To access the factory settings, press the **Prg** and **Esc** buttons simultaneously and the Enter Password screen will appear.

**CAUTION: Before entering the Factory Setup area, be aware that all components within this section have been pre-configured by the unit manufacturer. Changes to the existing setup may affect the operation of the system. Before making changes within this section, it is extremely important to write down the existing settings of the screen that will be changed.**

To enter the Factory settings area of the program, press the **Prg** button. Next, press the ← button to move the cursor under the password digits. Press the ↑ button and hold it down until the desired password level displays on the screen then press ← again. Password levels are as follows:

Basic Operating Parameters  
Password: 0717  
(Allows operator to view and change system basic digital and analog inputs and outputs.)

Advanced Operating Parameters (Systems without Real Time Clocks)  
Password: 0748  
(Allows operator to view and change system basic digital and analog inputs and outputs.)

Advanced Operating Parameters (Systems with Real Time Clocks)  
Password: 0717 plus the Day Number of the Month  
(Allows operator to view and change system basic digital and analog inputs and outputs.)  
Example: The date of the month is the 17<sup>th</sup>. Add 717 + 17 for a password of 0734.

U01

## FACTORY SETUP

The Factory Setup screen allows the operator to know they've entered the factory settings section of the program. Press the ↓ button one time to get to the digital input setup section.

For special applications, refer to the electrical diagram and addendums provided with the unit ordered for digital input configuration.

The **SELECT DIG IN** screens, allows the operator to know which digital input options the customer has with their system. The devices that are connected to these digital inputs are primarily used for alarms on standard and optional United CoolAir provided applications. If the component tied to digital input opens during operation, Marvel Main Board will read the open circuit and provide the appropriate alarm or notification and shut down each related function connected with that particular digital input. To switch a device ON or OFF, press the ↑ or ↓ button to change to Yes or No then press ← to accept the change. Continue pressing ← to move the cursor to the next screen under the factory settings.

**NOTE:** On software versions 4.5 and higher, the cursor will be blinking in the upper left hand corner of the page. Press the ↑ or ↓ button to move to the page where the changes are desired then press the ← button while on that page to move to the location of the component to change.

### SELECT DIG IN

1 AIRFLOW	>YES
2 HEAT LIMIT	>YES
3 FILTER	>YES

**Digital Input 1** – is used to configure the system for a Loss of Air Flow Alarm (Airflow) or a Duct Pressure Switch (Pressure Stat). When the device opens, all functions outputs will be shut down to protect the system. Once the problem has been located and corrected the unit must be reset manually through the ⏏ button and System Enables menu.

**Digital Input 2** – is used to configure the system for a Heater High Limit Alarm (Heat Limit). This alarm will be in the form of a shut down of all staged heat. The Heater High Limit Switch will automatically reset once the temperatures falls below the reset point. The reset will allow the heater elements to re-energize however; the alarm will remain audible and appear on the Marvel Terminal unit requiring the ⏏ button to be pressed.

**Digital Input 3** – is used to configure the system for a Dirty Air Filter Switch (Filter). This alarm will be in the form of a notification only.

### SELECT DIG IN

4 DRAIN	>YES
5 C1 LOW PRES	>YES
6 C1 HIGH PRES	>YES

**Digital Input 4** – is used to configure the system for a Drain Pan Overflow Alarm (Drain), a Freeze Stat Alarm (Freeze), or both Drain and Freeze. If the switch(s) opens, all compressors that are operating are shut down and locked out from operation until the reason for failure is located and corrected. The system must be reset by pressing and clearing the alarm and reset to ON manually through the System Enables menu.

**Digital Input 5** – is used to configure Compressor 1 for a Low Pressure Safety Alarm (C1 Low Press). If the Compressor 1 Low Pressure switch opens, Compressor 1 is shut down and locked out from operation. A manual reset is required of the compressor system through the System Enables menu. To clear the audible and visual alarm the  button must be pressed and held for a few seconds. The reason for failure must be located and corrected.

**Digital Input 6** – is used to configure Compressor 1 for a High Pressure Safety Alarm (C1 High Press). If the Compressor 1 High Pressure switch opens, Compressor 1 is shut down and locked out from operation. A manual reset is required of the compressor system through the System Enables menu. The alarm must be reset by pressing the  button. The reason for failure must be located and corrected.

SELECT DIG IN		
7	C2 LOW PRES	>YES
8	C2 HIGH PRES	>YES
9	SMOKE DETECT	>YES

**Digital Input 7** – is used to configure Compressor 2 for a Low Pressure Safety Alarm (C2 Low Press). If the Compressor 2 Low Pressure switch opens, Compressor 2 is shut down and locked out from operation. A manual reset is required of the compressor system through the System Enables menu. To clear the audible and visual alarm the  button must be pressed and held for a few seconds. The reason for failure must be located and corrected.

**Digital Input 8** – is used to configure Compressor 2 for a High Pressure Safety Alarm (C2 High Press). If the Compressor 2 High Pressure switch opens, Compressor 2 is shut down and locked out from operation. A manual reset is required of the compressor system through the System Enables menu. To clear the audible and visual alarm the  button must be pressed and held for a few seconds. The reason for failure must be located and corrected.

**Digital Input 9** – is used to configure the system for a Smoke Detector Alarm and Fire Shut Down (Smoke Detect). When the duct mounted smoke detector contact opens, the unit is completely shut down from operation. Once the problem is located and corrected, the unit must be re-enabled through the System Enables menu. To clear the audible and visual alarm the  button must be pressed and held for a few seconds.

SELECT DIG IN		
10	REMOTE ON	>YES
11	C3 LOW PRES	>YES
12	C3 HIGH PRES	>YES





**Digital Input 10** – is used to configure the system for a Remote ON switch (Requires customer provided mounted and wired Remote ON/OFF switch). When the customer opens the switch, the unit will shut down. When the switch is closed, the unit will switch to ON.

**Digital Input 11** – is used to configure Compressor 3 for a Low Pressure Safety Alarm (C3 Low Press). If the Compressor 3 Low Pressure switch opens, Compressor 3 is shut down and locked out from operation. A manual reset is required of the compressor system through the System Enables menu. To clear the audible and visual alarm the  button must be pressed and held for a few seconds. The reason for failure must be located and corrected.

**Digital Input 12** – is used to configure Compressor 3 for a High Pressure Safety Alarm (C3 High Press). If the Compressor 3 High Pressure switch opens, Compressor 3 is shut down and locked out from operation. A manual reset is required of the compressor system through the System Enables menu. To clear the audible and visual alarm the  button must be pressed and held for a few seconds. The reason for failure must be located and corrected.

The **INSTALL SENSORS** screens, allows the operator to know which analog inputs options the customer has with their system. The devices that are connected to these digital inputs are primarily used for temperature, humidity, and pressure control applications. For special applications, refer to the electrical diagram and addendums provided with this literature for analog input configuration.

<b>INSTALL SENSORS</b>	
1	RETURN/ROOM T >YES
2	OA TEMP >YES
3	FREE-COOL TEMP >YES





The install sensor screen for Return/Room T (Return/Room Temperature), OA Temp (Outdoor Air Temperature), and Free Cool Temp (Water Side Economizer Water Temperature), sets the program to read the temperatures from each device and allows the system to stage/modulate based on their readings. To switch a device ON or OFF, press the  or  button to change to Yes or No then press  to accept the change. Continue pressing  to move the cursor to the next screen under the factory settings.

The analog inputs 4, 5, and 6 can be configured as follows:

**Analog Input 1** – This input is used to configure the system to read a Room/Return Air temperature sensor for standard cooling and heating applications.

**Analog Input 2** – This input is used to configure the system to read an Outdoor Air temperature sensor for airside economizer or heat pump low outdoor temp conditions.

**Analog Input 3** – This input is used to configure the system for a Free Cool Coil entering Water Temperature sensor.

To switch a device ON or OFF, press the  or  button to change to Yes or No or set the variable input to the desired selection then press  to accept the change. Continue pressing  to move the cursor to the next screen under the factory settings.

<b>INSTALL SENSORS</b>	
4	DISCHARGE TEMP >YES
5	RETURN HUMID >YES
6	ROOM PRESSURE >YES

The analog inputs 4, 5, and 6 can be configured as follows:

**Analog Input 4** – This input is used to configure the system to read a discharge air temperature sensor or a potentiometer for external temperature adjusted through and external source other than the Marvel Terminal.

**Analog Input 5** – This input must be configured for Room/Return Humidity (Yes) when a Room/Return Humidity sensor is connected to this input.

**Analog Input 6** – This input must be configured for Room Pressure or Duct Pressure for the type of application. Select Room Pressure when the pressure transducer is used as Room Pressure control or Duct Pressure when the pressure transducer is used as a duct pressure control.

To switch a device ON or OFF, press the **↑** or **↓** button to change to Yes or No or set the variable input to the desired selection then press **↵** to accept the change. Continue pressing **↵** to move the cursor to the next screen under the factory settings.

```
INSTALL SENSORS
7 OA HUMIDITY    >YES
8 OFF
```

**Analog Input 5** – This input must be configured for Outdoor Air Humidity (Yes) when an Outdoor Air Humidity sensor is connected to this input.

**Analog Input 6** – This input must be configured for Room Pressure or Duct Pressure for the type of application. Select Room Pressure when the pressure transducer is used as Room Pressure control or Duct Pressure when the pressure transducer is used as a duct pressure control.

The install sensor screen for OA Humidity (Outdoor Air Humidity), sets the programs to read the Humidity, and Room Pressure for the particular device connected and allows the system to stage/modulate based on their readings. To switch a device ON or OFF, press the **↑** or **↓** button to change to Yes or No then press **↵** to accept the change. Continue pressing **↵** to move the cursor to the next screen under the factory settings.

The **SELECT OUTPUT** screens, allows the operator to know which digital output options the customer has with their system. The devices that are connected to these digital outputs are primarily used for standard option applications. For special applications, refer to the electrical diagram and addendums provided with this literature for digital output configuration.

```
SELECT OUTPUT
RELAY 1>FAN
RELAY 2>COMPRESSOR 1
RELAY 3>COMPRESSOR 2
```

The Select Output screen for Relay 1, Relay 2, and Relay 3 is used to configure the Factory provided options listed below.

**Relay 1** can be configured for Off for no function or Fan to energize the contactor for the supply air blower.

**Relay 2** can be configured for Off for no function; Compressor 1 to operate a contactor for the first stage compressor; Cool Open to open a water valve for a chilled water coil.

**Relay 3** can be configured for Off for no function, Compressor 2 to operate a contactor for the second stage compressor; Cool Close to drive a water valve for a chilled water coil.

To set each component on or off, press the ← button to move the cursor to the desired component to change. Press the ↑ or ↓ button to toggle to the desired control function then press ← to accept the change.

```
SELECT OUTPUT
RELAY 4>HEATER 1
RELAY 5>HEATER 2
RELAY 6>HEATER 3
```

The Select Output screen for Relay 4, Relay 5, and Relay 6 is used to configure the Factory provided options listed below.

**Relay 4** can be configured for Off for no function; Heat Open to drive a water valve open; Heater 1 to energize a contactor for the first stage of optional electric heat.

**Relay 5** can be configured for Off for no function; Heat Close to drive a water valve closed; Heater 2 to energize a contactor for the second stage of optional electric heat.

**Relay 6** can be configured for Off for no function, Alarm Out for remote annunciation when there is a critical alarm with the system (this output typically connects to a field provided buzzer or indicator light); Heater 2 to energize a contactor for the second stage of optional electric heat.

To set each component on or off, press the ← button to move the cursor to the desired component to change. Press the ↑ or ↓ button to toggle to the desired control function then press ← to accept the change.

```
SELECT OUTPUT
RELAY 7>OFF
RELAY 8>COMPRESSOR 3
RELAY 9>FREE COOL
```

The Select Output screen for Relay 7, Relay 8, and Relay 9 is used to configure the Factory provided options listed below.

**Relay 7** can be configured for Off for no function; OSA Damper to control an Outdoor Air Damper; Fan Low SP is used to control the speed of the supply blower motor when a two speed motor is used; C2 Un-loader to add an un-loader to operate in sequence with Compressor 2.

**Relay 8** can be configured for Off for no function; Condenser Fan to operate a contactor for the condenser fan motor; OSA Damper to control another Outdoor Air Damper; or another un-loader to operate in sequence with Compressor 1.

**Relay 9** can be configured for Off for no function; Fan Low SP to control the speed of the supply blower motor when a two speed motor is used; Alarm Out for annunciation when there is a critical alarm with the system (this output typically connects to a field provided buzzer or indicator light); Heater 4 is used when the unit has an optional fourth stage of heating connected to the system; Free Cool when the unit has an optional Free Cool coil.

To set each component on or off, press the ← button to move the cursor to the desired component to change. Press the ↑ or ↓ button to toggle to the desired control function then press ← accept the change.

```
SELECT OUTPUT
RELAY 10>HUMIDIFIER
RELAY 11>COND FAN
RELAY 12>PUMP
```

The Select Output screen for Relay 10, Relay 11, and Relay 12 is used to configure the Factory provided options listed below.

**Relay 10** can be configured for Off for no function; Humidifier to control the on/off operation of a humidifier; Dehumidifier to control the system like a dehumidifier; Pressure Close to control a damper actuator for Room Pressure control; Econ Close to control dampers for the Airside Economizer function.

**Relay 11** can be configured for Off for no function; Humidifier to control the on/off operation of a humidifier; Dehumidifier to control the system like a dehumidifier; Pressure Close to control a damper actuator for Room Pressure control; Econ Close to control dampers for the Airside Economizer function.

**Relay 12** can be configured for Off for no function; Fan Low SP to control the speed of the supply blower motor when a two speed motor is used; Alarm Out for annunciation when there is a critical alarm with the system (this output typically connects to a field provided buzzer or indicator light); Heater 4 is used when the unit has an optional fourth stage of heating connected to the system; Free Cool when the unit has an optional Free Cool coil.

To set each component on or off, press the ← button to move the cursor to the desired component to change. Press the ↑ or ↓ button to toggle to the desired control function then press ← to accept the change.

```
U01  ANALOG OUTPUTS

OUT 1> MOD HEAT  >DIR
OUT 2> ECONO     >REV
```

This screen is used to select the analog outputs of the system. The following is a breakdown of the analog output selections and the functions they perform:

**MOD HEAT** – Selects the analog output for Modulating Heat mode of operation. The heating source can be SCR controlled electric heat coils, Hot Water Coil, or Hot Gas Reheat.

**ECONO** – Selects the analog output for Airside Economizer mode of operation. For Airside Economizer mode to function, the system also requires an Outdoor Temperature and Humidity Sensor (typically duct mounted factory provided with option field installed) and a space or return temperature and humidity sensor factory provide field installed. When this option is ordered and set to ECONO, the analog output is used to drive the damper actuators.

**PRESS** – Selects the analog output to perform Pressure Control. This output is connected with analog output 6 which must be selected for Room or Duct Pressure Control.

**CL VALVE** – Selects the analog output to modulate an actuator driven water valve to maintain the cooling set point.

**STANDARD-HG** – This analog output is used in connection with the **Unit Type** control screen. The Unit Type selected must be set to Hot Gas Ctl. The unit must also have the hot gas bypass option. The controller will operate the compressors based on the Room/Return Air Temperature and Room/Return Temperature Set point. As long as the discharge air temperature remains above 55°F, hot gas will not be modulated. As the discharge air temperature falls below 55°F, Compressor 2 if applicable will be shut down and the analog output to the hot gas bypass valve will be modulated to introduce hot refrigerant gas into the evaporator coil to maintain the discharge air temperature as close to 55°F as possible. If the temperature continues to fall once the analog output is completely modulated to +10 vdc (full hot gas bypass), Compressor 1 will be shut down.

**DISCH-HG** – This analog output is used in connection with the **Unit Type** control screen. The Unit Type selected must be set to Hot Gas Ctl2. When the Unit Type is selected to Hot Gas Ctl2, the controller modulates the analog output to add hot gas to the evaporator to try to maintain the Discharge Air Temperature Set Point based upon the actual Discharge Air Temperature. When the system has one compressor, this analog output will modulate a hot gas bypass valve when the cooling demand is less than 100%. The cooling demand will be 100% when the discharge air temperature is equal to the discharge air temperature set point plus band set point.

In a two compressor application when cooling demand is at 100%, the analog output will remain at 0 vdc. As the discharge temperature starts to fall toward the discharge temperature set point, the cooling demand for each compressor shall become less. At this point, this analog output shall be modulated from 0-10 vdc to maintain the cooling demand. When the cooling demand becomes less than 50%, Compressor 2 is shut down. If the discharge temperature continues to fall the cooling demand continues to become less and the valve is modulated completely open and Compressor 1 is shut down because the Cooling Demand is satisfied.

U01 ANALOG OUTPUTS VOLTAGE RANGE AO1>00.0vdc- 10.0vdc AO2>00.0vdc- 10.0vdc
---

This screen allows for setting of the analog output range. For instance if the valve provided is 2 to 10 vdc, instead of allowing the setup range to remain at 0 vdc for the low range, it could be readjust to correct

```
U01 CHANGE PASSWORDS
LEVEL 1>0000
LEVEL 2>0717
Protect Setpts? ON
```

This screen is used to set the Level 1 and Level 2 Passwords. The Level 1 Password is used to prevent unauthorized users from accessing screens other than the main **Esc** screen or service run hours. The Level 1 password protects the set points, information, and inputs and outputs section when set.

The Level 2 password protects the Factory Settings area. The Factory Settings area sets the unit's specific system components that are required to operate. The settings must not be changed unless the Factory or United CoolAir Distributors recommend the changes.

Protect Set Pts allows for customers to set a password for their set points to prevent unauthorized users from changing their desired settings.

```
U01      TEMP UNITS
MODE: FAHRENHEIT
CHANGE SET POINTS
TO FAHRENHEIT
```

The Temp Units screen allows the customer to set the type of temperature control they wish to perform (Fahrenheit or Centigrade).

```
U01  SYSTEM DELAYS
DEL ON>030 OFF >00s
FAN OPERATION >ON
MIN ON>030 OFF>030s
```

The System Delays screen is used to change the functions of the blower operation.

**DEL ON** is the delay time in seconds before the supply air blower starts when the system is set to ON using the Enter button or setting it to on in the I/O menu.

**DEL OFF** is the delay time in seconds before the blower shuts down at the end of a cycle or when the system goes into unoccupied mode or set to the off position. Fan operation must be set to Auto for this function to operate properly.

**FAN OPERATION** is the setup for fan operation continuous or automatically starts and shuts down based on demand. Set to Auto for the fan to operate only when there is a demand for cooling, heating, humidification, or dehumidification.

**MIN ON** is the Minimum amount of time the blower must remain on before it can be shut down. This function is used only in Auto Fan operating mode when the conditions are satisfied and during night set back mode.

**MIN OFF** is the Minimum amount of time the blower must remain off before it can be restarted. This function is used only in Auto Fan operating mode when the conditions are satisfied and during night set back mode.

U01 RAMP CONTROL		
	TYPE	INT TIME
TEMP	>P	120s
HUM	>P	120s

Ramp Control is used in smart logic control of the system. Temperature and Humidity control is based around Proportional (P) or Proportional and Integral (P+I).

**Proportional** is direct acting which means the control will for instance read the temperature is above the set point plus ½ the band for 100% cooling demand before energizing the digital output(s) for cooling and likewise the humidity and humidity set points.

**Proportional and Integral** will react to the readings as they are changing. For instance if the temperature is not yet equal to the temperature set point plus ½ the band setting but is approaching the temperature set point plus ½ the band set points, the demand will make an immediate increase causing cooling to energize a bit early in efforts to proactively determine what will be the most effective operation to get the unit to set point quicker. This method monitors the rate of change of temperature and humidity over time.

UNIT TYPE	
SYSTEM>	STANDARD

The Unit Type screen is used to set up the type of control the Marvel system will provide.

**System> Standard** – With the standard control setup selected, the control will perform standard climate control (cooling, heating, humidification, and dehumidification).

**System> Hot Gas Ctl** – With the Hot Gas Ctl control setup selected, the control modulates the modulating hot gas bypass valve option to maintain discharge air temperature. Compressors operate based on the cooling demand from Return Air Temperature then the discharge air temperature is adjusted by the modulating the hot gas valve to maintain the discharge temperature set point.

UNIT TYPE	
SYSTEM>	HOT GAS CTL2
Control VFD?	No

**System> Hot Gas Ctl2** – With the Hot Gas Ctl2 control setup selected, the control modulates the modulating hot gas bypass valve option to maintain discharge air temperature. The cooling and compressor demands are controlled based upon discharge air temperature and set point with this

method unlike standard cooling and standard modulating hot gas bypass which uses the room/return air temperature sensor to control the on/off points of the compressor.

Morning Warm-up By Time: Off By BMS: Off
--

Allows customers to add a morning warm-up feature. There are two methods of morning warmup available. By time which when this is set to ON, Time Settings appear under the Clock Menu. By BMS allows the customer to provide a dry contact closure to the Warm-Up Digital Input.

U01      Digital Input 1 AIRFLOW SWITCH> CLOSE ALARM DELAY:      005s Flow Check Del:      030s
--

This screen is used to select the setup of Digital Input 1 or Air Flow Switch.

**Air Flow Switch** is used to help set up the correct read time of the switch which becomes extremely important when VFDs are used on the evaporator blower. Because VFDs tend to ramp up slowly, it takes additional time for the air flow switch to make. Air Flow Switch is a read point so that it will switch from open to close or close to open depending on when the unit has the required air flow.

**Alarm Delay** allows for adjustment of the how much time must elapse before providing an alarm. The Air Flow Switch must either first close the contact or the Flow Check Delay time must time out.

**Flow Check Delay** is the amount of delay time that is required before the system checks the air flow switch.

U01      COMP DELAYS LOW PRESS DEL>040sec MINIMUM ON      >300sec MINIMUM OFF      >300sec
---

**Low Pressure Delay** is used in applications with the low ambient control flooded condenser option. The Low Pressure Delay is the amount of delay time from the start of a run cycle for the compressor until the low pressure digital input is read by the controller.

**Minimum ON** is the amount of time the compressor must remain on after the start of a run cycle. This Minimum ON time is designed to protect the compressor from short cycling.

**Minimum OFF** is the amount of time the compressor must remain off after the stop of a run cycle. This Minimum OFF time is designed to protect the compressor from short cycling.

```
U01    COMP DEL/CTRL
TIME BET COMPS >060sec
COMP ROTATE   >OFF
```

The compressor delay and control screen is used to set the amount of delay between compressors and compressor rotation within the unit. Time Bet Comps is the amount of delay between each compressor staging on. If the cooling demand is high the time between compressors will prevent two compressors from cycling on at the exact same time. The Comp Rotate sets the compressors to rotate at compressor stage up and stage down. Upon compressor start, the system will always energize Compressor 1 up to the maximum amount of compressors. Upon compressor shut down, Compressor 1 will be shut down first with the compressor that was staged on last shutting down last.

```
U01    ECONOMIZER
ECON ENABLE>    OFF
DAMPER MINIMUM> 010%
```

This screen is used to set the functions of the Airside Economizer option.

**Econ Enable** is used to enable (turn on) the airside economizer function.

**Damper Minimum** is the minimum position required of the actuators to maintain fresh air requirements.

NOTE: Airside Economizer will not function with the ECON Enable set to the OFF position. Econ Enable must be set to ON in order for the controller to perform the airside economizer function.

```
U01    ECONOMIZER
Comp Assist>    OFF
Assist Del>     010m
```

**Comp Assist** when Compressor Assist is set to ON, compressors will assist the Airside Economizer Function as long as the cooling demand remains at 100% for the Assist Delay Time.

**Assist Del** The amount of time the compressor will remain off when Compressor Assist is set to on and the Cooling Demand remains at 100%

```
U01    CL/HT CONTROL
        START  END
COOLING > 010  > 100%
HEATING > 010  > 100%
```

With this screen, a dead band can be introduced to the cooling and heating demands based upon the selected start and end values. Setting the start value would start the cooling or heating process earlier than the demand is calling. For instance if the cooling start is set to 10%, the compressors would energize earlier than the room/return air temperature increasing above the temperature set point plus ½ the band set point. If the end value was set to 90%, the function would end at 90% of the demand being satisfied and it would not fully reach the intended set point value.

```
U01  HU/DH CONTROL
      START END
HUMIDIFY> 010  > 100%
DEHUMID> 010  > 100%
```

With this screen, a dead band can be introduced to the humidification and dehumidification demands based upon the selected start and end values. Setting the start value would start the humidification and dehumidification process earlier than the than the demand is calling. For instance if the dehumidify start is set to 10%, the compressors would energize earlier than the room/return air humidity increasing above the humidity set point plus ½ the band set point. If the end value was set to 90%, the function would end at 90% of the demand being satisfied and it would not fully reach the intended set point value.

```
U01
  ENABLE ENTER KEY
  MENU SYSTEM> OFF
```

This screen is used to set the controller to operate using a PCOT or a PGD display. This literature was designed for units with the PCOT Terminal (Wall Control). The MENU SYSTEM must be set to OFF for the Marvel Wall Control to work correctly with the controller. When a PGD display (6-button) is used

```
U01 COMMUNICATIONS
NETWORK CLOCK> OFF
IDENT>001 BAUD>19200
PROTOCOL>
```

The Communications screen is used to set of communications network for Building Management System interface.

**NETWORK CLOCK** must be set to ON when there are multiple units through one communications board for BMS setup.

**IDENT** is the setting for each particular Marvel Main Board. Each Main Board must have its ID own identification number in the communications network. This is how the Building Management System identifies each unit in the network.

**BAUD** is the rate of communication that the Marvel Main Board communicates with the BMS System. Each specific Building Management System communicates at a set Baud Rate in bits per

second (bps). The communications baud rate of the Marvel Main Board must match the baud rate the Building Management System that it communicates with.

**PROTOCOL** is used to set the type of supervisory (or BMS) system the Marvel Main Board will interface with.

## **MARVEL MAIN BOARD LAYOUT**

The Marvel Main Board is the core of the unit and will operate stand-alone without the need for the Terminal unit. The Main Board is where all sensors and control devices are connected. Figure 14 – Main Board illustrates the Main Board with a description of the on board components as well as connections.

1. Main Board input power requires 50 VA or greater of 24 VAC power from unit transformer.
2. Main Board input fuse. 2 Amp/250 VAC Rated. 5 mm x 20 mm BUSS Type Fuse
3. PLAN connection. Allows networking of multiple units.
4. RJ-12 connector to connect the Marvel Main Board to the Marvel Terminal.
5. Analog Outputs used for controlling modulating 0-10 VDC.
6. Digital Inputs used for safety devices and optional field accessories.
7. Digital Outputs terminal blocks to control ON/OFF devices.
8. Digital Output Relays.
9. Optional plug-in Real Time Clock Board.
10. Analog Inputs used for reading the sensors.
11. Jumper location for selecting active sensor input type 0-10 VDC or 0-20 mADC.
12. Optional plug-in RS232/RS485 Serial Communication Boards.
13. On-Board Flash Memory. Contains the control software.

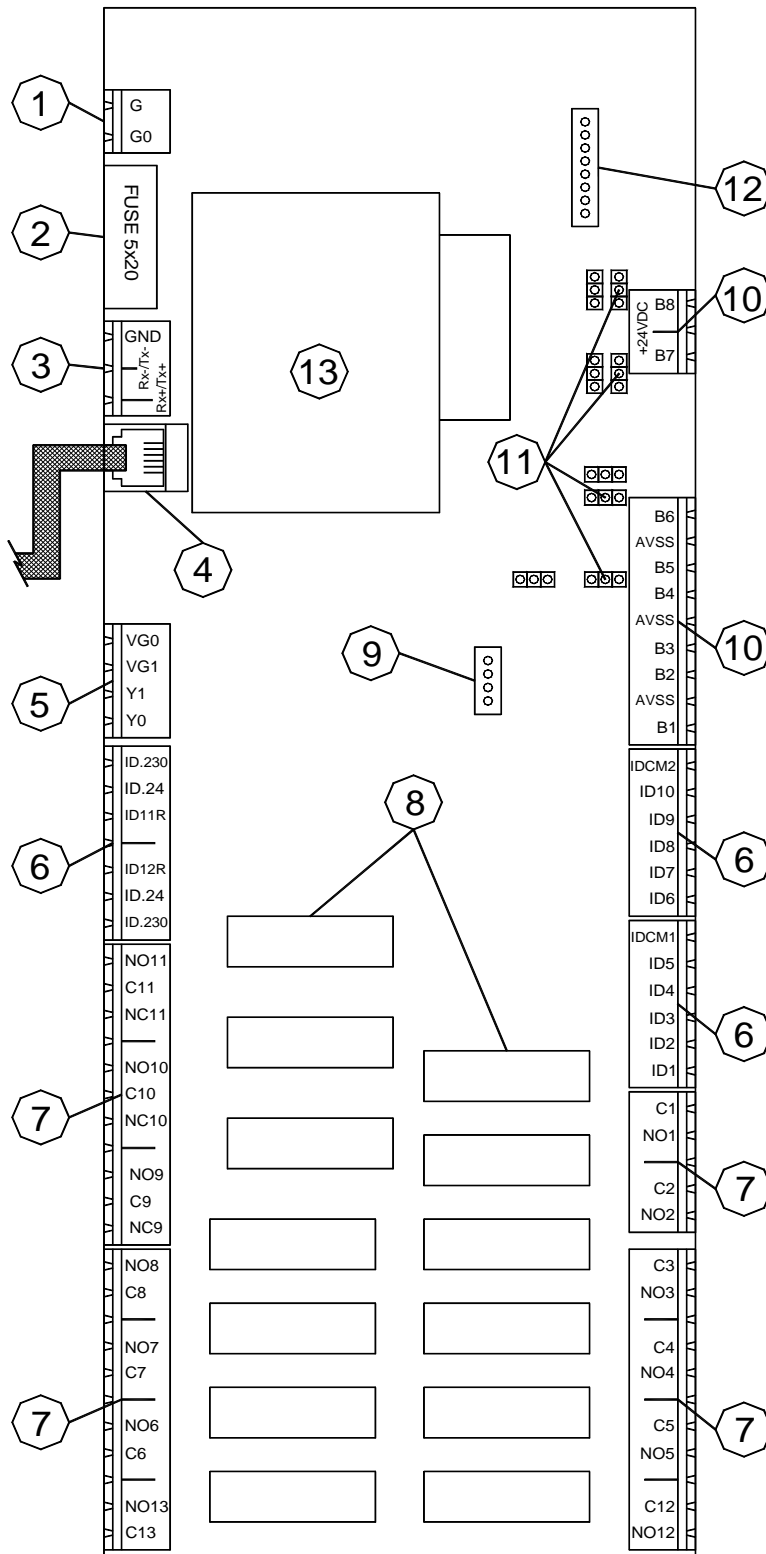
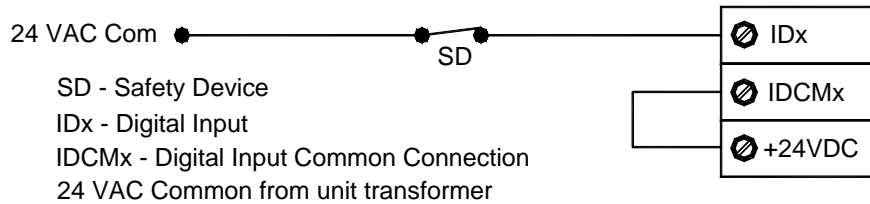

Figure 14 – Board Layout

# INPUT WIRING

## Digital Inputs

The digital inputs are designed to work with 24 VAC or 24 VDC. When using the digital inputs with a dc voltage source, a 24 V AC/DC common must be wired to the actual digital input, and must also be the same as the connection to the G0 terminal which is normally referenced to ground. The +24 VDC would then be wired directly to the IDCMx or common for the digital input. Refer to Figure 15 – Digital Input Termination References for further details.



**Figure 15 – Digital Input Termination References**

## Analog Inputs

A total of eight Analog Inputs are provided for reading Room/Return/Outdoor/Discharge Air Temperatures, Room/Return/Outdoor Air Humidity, Room Pressures, and VFD Feedback signals. The B1 through B4 are reserved as Resistive, Negative Temperature Coefficient (NTC) type temperature sensor sensors. The NTC temperature sensors are connected as shown in Figure 16 – Temperature Sensor Termination References. There is no polarity to the sensors.



**Figure 16 – Temperature Sensor Termination References**

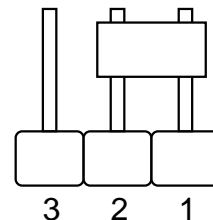

**Figure 17 – 0 to 20 mA Sensor Termination References**

B5 through B8 are reserved for active sensor inputs that may be either 0-1 VDC or 0-20 mA. The preference is selected through jumpers J14 and J15. Refer to Figure 17 – 0 to 20 mA Sensor Termination References. Terminals B5 through B8 are the signal input or negative (-) connection of the sensor / feedback from the sensor to the control board. Connect the negative side of the sensor to the appropriate input B5, B6, B7, or B8. The +24 vdc terminals is used to power the positive (+) terminal of the sensor and should be connected to the + (positive side) input of the sensor.

## Digital Outputs

There are 13 Digital Output Relays capable of handling up to 10 Amps Resistive at 1 Amp Inductive loading at 250 VAC. To power a control device (contactor, starter, solenoid coil, etc.) connect the neutral side of the 24 VAC power supply to the control device. Connect the hot side of the 24 VAC power supply through the common C(x) of the digital output relay as shown in Figure 18 – Digital Output Termination References.



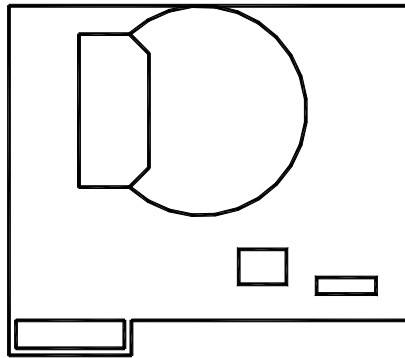

Figure 20 – Real Time Clock Board

## BUILDING MANAGEMENT SYSTEMS (BMS SYSTEMS)

Several methods of supervisory systems may be used to communicate with the Marvel Main Board which allow for monitoring of the systems readings, changing/offsetting of set points and remotely view alarm status. Refer to Marvel Communications Literature Form Number: MARCOMM. The following is a list of BMS Systems the Marvel Control can interface with:

BACnet  
ModBus  
pCOWeb  
LonWorks

## SYSTEM NETWORKING

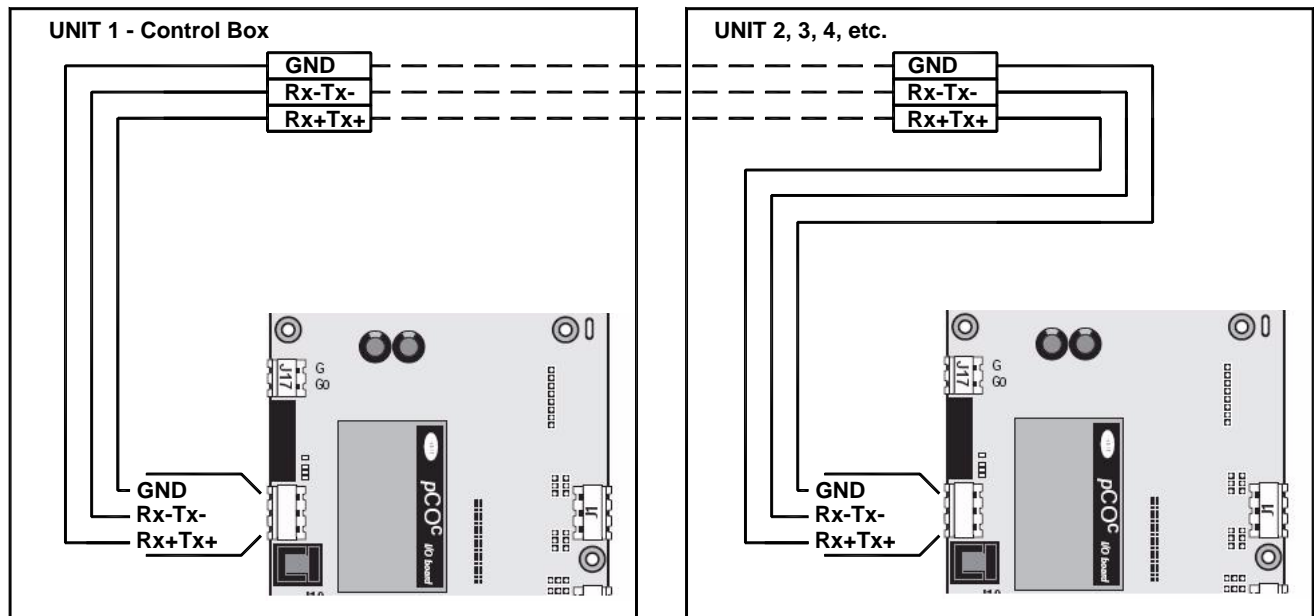

Two or multiple units may be networked as shown in Figure 21 – System Networking. The networks are preconfigured during the operational testing at the factory. If for any reason the units lose their networking setup, follow these procedures for re-configuring the network setup.

1. Connect the network wiring between each unit as shown in Figure 20.
  - a. Network wiring between each unit must be installed between each unit as follows:
    - i. Unit 1 connects to Unit 2
    - ii. Unit 2 to Unit 3
    - iii. Unit 3 to Unit 4 and so on.
    - iv. DO NOT connect between units in a star configuration.)





**FIELD WIRING BETWEEN UNITS - - - - -**  
 Must be 18-22 AWG at 3 conductor shielded with drain wire.  
 Connect the drain wire to unit chassis ground at one unit only.

**Figure 21 – System Networking**

2. Locate and remove the 4 foot telephone cable from the Marvel Main Board and disconnect the coupling. Also locate the Marvel Terminal (Wall Mount Control) and remove it from the wall as it will be required to perform configuration at each unit.
3. Connect the Marvel Terminal to one unit at a time starting with Unit 1.
4. Press the  and  buttons simultaneously while applying power to the unit. These buttons must be held until the following screen appears:

pLan address: 0  
 UP: increase  
 DOWN: decrease  
 ENTER: save & exit

5. Once the pLan screen appears, enter the pLan address (unit ID) number by pressing the  or  buttons.
6. Once the number of the unit being configured appears next to I/O board Adr, press the enter button to exit and save. In a second or two a blank screen will appear.
7. Disconnect power to the unit at this time.
8. With the dip switches remaining in the off position, repeat steps 5-8 on the remaining units incrementing each unit id by 1 during the configuration of each unit.
9. Once all units have an identification number in the pLan network, set dip switches 1 and 5 to ON or Up. Setting these numbers to ON will id the Marvel Terminal unit to the number 17.

10. Reconnect the Marvel Terminal to Unit 1 and place the controller back at the location of installation.
11. Apply power to every unit in the network and perform the following steps.
12. Press the ←, and ↑ or ↓ buttons simultaneously until the following screen appears in the display:

```
Terminal Adr: 17
I/O board Adr:--
```

13. Terminal Adr: 17 will automatically appear. Press the and ↑ to set the I/O Board Address number (Unit ID) starting with 1.
14. Press ← one time and the following screen will appear:

```
Terminal config
Press ENTER
to continue
```

15. Press ← again the following screen will appear:

```
P:xx Adr Priv/Shared
Trm1 None --
Trm2 None --
Trm3 None -- Ok? No
```

16. Set the Marvel Terminal Trm1 to 17 which is the number the dip switches were set to when both 1 and 5 were set to ON in step 10. To do this, press ← to drop the cursor to the Trm1: None line.
17. Press the ↑ button to set the terminal to a 17.
18. Press the ← button to save and the cursor will reposition under the double dash (--).
19. Press the ↑ button until the Sh appears in the space then press the ← button and continue to press the ← button until the cursor is positioned under the Ok?No.
20. Press the ↑ to select the No to Yes and press ← again to save and exit.
21. Repeat steps 13 through 21 incrementing by 1 to add the remaining units into the network.

## MARVEL MAIN BOARD CONNECTION POINTS

Item #	Terminal	Description	Software Use
J17 - 1	G	Power supply 24 VAC Input	
J17 - 2	G0	Power supply 24 VAC Common	
J19	Terminal	6-wire RJ11 telephone connection for Terminal	
J20 - 1	VG0	24 VAC Common to power the Opto-Insulated Analog Outputs	
J20 - 2	VG1	24 VAC Input to power the Opto-Insulated Analog Outputs	
J20 - 3	Y0	Analog Output 1 (0-10 Vdc)	Hot Gas, Economizer, Pressure, Humidifier, Chilled Water Modulating Heat
J20 - 4	Y1	Analog Output 2 (0-10 Vdc)	Hot Gas, Economizer, Pressure, Humidifier, Chilled Water Modulating Heat
J21 - 1	ID.230	No Connection	
J21 - 2	ID.24	+24 VAC	Compressor 3 Low Pressure
J21 - 3	ID11R	Digital input 11 (24 VAC Com)	
J21 - 4		No Connection	
J21 - 5	ID12R	Common Digital Input 12	Compressor 3 High Pressure
J21 - 6	ID.24	Digital input 12 (24 VAC Com)	
J21 - 7	ID.230	No connection	
J22 - 1	NO11	Relay 11 Normally Open Contact	Humidifier, Dehumidifier, Pressure Open, Economizer Open
J22 - 2	C11	Relay Output 11 Common	

Item #	Terminal	Description	Software Use
J22 - 3	NC11	Relay 11 Normally Closed Contact	
J22 - 4		No connection	
J22 - 5	NO10	Relay 10 Normally Open Contact	Humidifier
J22 - 6	C10	Relay Output 10 Common	
J22 - 7	NC10	Relay 10 Normally Closed Contact	
J22 - 8		No connection	
J22 - 9	NO9	Relay 9 Normally Open Contact	Free Cool, Heater 4, Alarm Out
J22 - 10	C9	Relay Output 9 Common	
J22 - 11	NC9	Relay 9 Normally Closed Contact	
J24 - 1	NO8	Relay 8 Normally Open Contact	Compressor 3
J24 - 2	C8	Relay Output 8 Common	
J24 - 3		No connection	
J24 - 4	NO7	Relay 7 Normally Open Contact	Outdoor Air Damper
J24 - 5	C7	Relay Output 7 Common	
J24 - 6		No Connection	
J24 - 7	NO6	Relay 6 Normally Open Contact	Heater 3 or Alarm Out
J24 - 8	C6	Relay Output 6 Common	

Item #	Terminal	Description	Software Use
J24 - 9		No Connection	
J24 - 10	NO13	Relay 13 Normally Open Contact	
J24 - 11	C13	Relay Output 13 Common	Open Output
J6 - 1	NO12	Relay 12 Normally Open Contact	
J6 - 2	C12	Relay Output 12 Common	Water Pump
J6 - 3		No Connection	
J6 - 4	NO5	Relay 5 Normally Open Contact	Heater 2 or Heat Close
J6 - 5	C5	Relay Output 5 Common	
J6 - 6		No Connection	
J6 - 7	NO4	Relay 4 Normally Open Contact	Heater 1 or Heat Open
J6 - 8	C4	Relay Output 4 Common	
J6 - 9		No Connection	
J6 - 10	NO3	Relay 3 Normally Open Contact	Compressor 2 or Cool Close
J6 - 11	C3	Relay Output 3 Common	
J5 - 1	NO2	Relay 2 Normally Open Contact	Compressor 1 or Cool Open
J5 - 2	C2	Relay Output 2 Common	
J5 - 3		No Connection	

Item #	Terminal	Description	Software Use
J5 - 4	NO1	Relay 1 Normally Open Contact	Fan (Supply Air Blower)
J5 - 5	C1	Relay Output 1 Common	
J4 - 1	ID1	Digital Input 1 (12 to 24 Vac/dc)	Airflow Loss or High Static Pressure
J4 - 2	ID2	Digital Input 2 (12 to 24 Vac/dc)	Smoke detector alarm
J4 - 3	ID3	Digital Input 3 (12 to 24 Vac/dc)	Dirty Filter
J4 - 4	ID4	Digital Input 4 (12 to 24 Vac/dc)	Drain Pan Overflow / Freeze Stat
J4 - 5	ID5	Digital Input 5 (12 to 24 Vac/dc)	Compressor 1 Low Pressure
J4 - 6	IDCM1	Common Input for Digital Inputs ID1-ID5 (+24 vdc from board)	
J3 - 1	ID6	Digital input no.6 (12 to 24 Vac/dc)	Compressor 1 High Pressure
J3 - 2	ID7	Digital Input 7 (12 to 24 Vac/dc)	Compressor 2 Low Pressure
J3 - 3	ID8	Digital Input 8 (12 to 24 Vac/dc)	Compressor 2 High Pressure alarm
J3 - 4	ID9	Digital Input 9 (12 to 24 Vac/dc)	Smoke/Fire Detector
J3 - 5	ID10	Digital Input 10 (12 to 24 Vac/dc)	Remote ON/OFF
J3 - 6	IDCM2	Common Input for Digital Inputs ID6-ID10 (+24 vdc from board)	
J2 - 1	B1	Analog Input 1 (NTC)	Room or return air temperature
J2 - 2	AVSS	Common Analog Inputs	
J2 - 3	B2	Analog Input 2 (NTC)	Discharge air temperature

Item #	Terminal	Description	Software Use
J2 - 4	B3	Analog Input 3 (NTC)	Coil temperature
J2 - 5	AVSS	Common Analog Inputs	
J2 - 6	B4	Analog Input 4 (NTC)	Outside air temperature
J2 - 7	B5	Analog Input 5 (0-1 Vdc or 0-20 mA)	Room or Return Air Humidity
J2 - 8	AVSS	Common analog inputs	
J2 - 9	B6	Analog Input 6 (0-1 Vdc or 0-20 mA)	Room Pressure Sensor
J1 - 1	B7	Analog Input 7 (0-1 Vdc or 0-20 mA)	Outside Air Humidity
J1 - 2	+24	DC power supply to active sensors (maximum 200 mA)	
J1 - 3	B8	Analog Input 8 (0-1 Vdc or 0-20 mA)	VFD Feedback

## PROGRAMMABLE PARAMETERS

Parameter/Description	Default	Lower/Upper Limits	Unit of Measure
Room / Return Temperature Setting	72	50/90	°F
Room / Return Temperature Band	5	0-99	°F
Room / Return Humidity Set point	50	35-65	% RH
Room / Return Humidity Band	10	0-99	%
Discharge Temperature Set Point	55	50-70	°F
Discharge Temperature Band	10	5-10	°F
Room / Return Hi / Low Temperature Alarm	80/60	50-120	°F
Room Hi Low Humidity Alarm	65/35	0/100	% RH
Enable Night Setback	OFF	On/Off	
Night Minimum ON	300	0-999	Seconds
Night Setback Hi / Low Temp	90/55	50-120	°F
Night Setback Hi / Low Humidity	65/35	0-100	% RH
Occupied / Unoccupied Times	6/18:00	0:00-23:59	Hours/Minutes
Supervisor Unit Identification	1	1-200	
Supervisor Baud Rate	19200	1200-19200	Baud